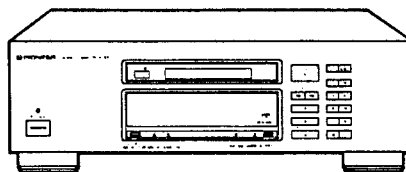


2496

PIONEER
The future of sound and vision.

Service Manual

Original



ORDER NO.
ARP1799

COMPACT DISC PLAYER

PD-71 PD-9300

MODELS PD-71 AND PD-9300 HAVE FOUR VERSIONS :

Type	Applicable model		Power requirement	Export destination
	PD-71	PD-9300		
KU/CA	○	-	AC120V only	U.S.A and Canada
HEM	-	○	AC220V,240V (switchable) *	European continent
HB	-	○	AC220V,240V (switchable) *	United kingdom
SD	○	-	AC110V,120 - 127V,220V,240V (switchable)	Kingdom of Saudi Arabia and General market

* Change the connection wires from the power transformer to the PRIMARY BOARD assembly.

- This service manual is applicable to the PD-71/KU/CA, SD, PD-9300/HEM and HB types.
- For the PD-71/SD type, please refer to pages 72.
- For the PD-9300/HEM and HB types, please refer to pages 73.
- Ce manuel pour le service comprend les explications en français de réglage.
- Este manual de servicio trata del método ajuste escrito en español.

CONTENTS

1. SAFETY INFORMATION	2	7. ADJUSTMENTS	30
2. EXPLODED VIEWS AND PARTS LIST	4	RÉGLAGE	44
3. PACKING	10	AJUSTE	58
4. SCHEMATIC DIAGRAM	14	8. FOR SD TYPE	72
5. P. C. BOARDS CONNECTION DIAGRAM	19	9. FOR PD - 9300/HEM AND HB TYPES	73
6. ELECTRICAL PARTS LIST	27	10. SPECIFICATIONS	75
		11. PANEL FACILITIES	76

PIONEER ELECTRONIC CORPORATION 4-1, Meguro 1-Chome, Meguro-ku, Tokyo 153, Japan
PIONEER ELECTRONICS SERVICE INC. P.O. Box 1760, Long Beach, California 90801 U.S.A.
PIONEER ELECTRONICS OF CANADA, INC. 505 Cochrane Drive, Markham, Ontario L3R 8E3 Canada
PIONEER ELECTRONIC [EUROPE] N.V. Keetberglaan 1, 2740 Beveren, Belgium
PIONEER ELECTRONICS AUSTRALIA PTY. LTD. 178-184 Boundary Road, Braeside, Victoria 3195, Australia TEL: [03] 580-9911
 © PIONEER ELECTRONIC CORPORATION 1989

IFJ MAR. 1989 Printed in Japan

2496

1. SAFETY INFORMATION

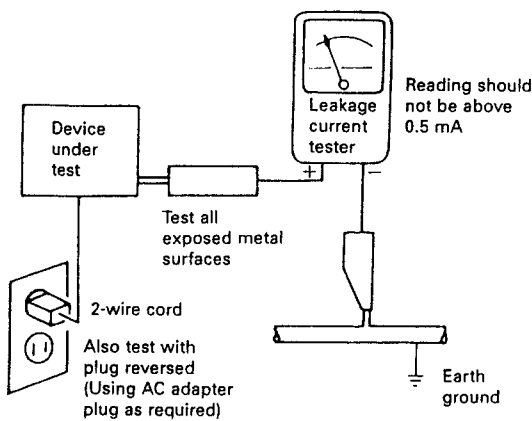
—(FOR USA MODEL ONLY)—

1. SAFETY PRECAUTIONS

The following check should be performed for the continued protection of the customer and service technician.

LEAKAGE CURRENT CHECK

Measure leakage current to a known earth ground (water pipe, conduit, etc.) by connecting a leakage current tester such as Simpson Model 229-2 or equivalent between the earth ground and all exposed metal parts of the appliance (input/output terminals, screwheads, metal overlays, control shaft, etc.). Plug the AC line cord of the appliance directly into a 120 V AC 60 Hz outlet and turn the AC power switch on. Any current measured must not exceed 0.5 mA.



AC Leakage Test

ANY MEASUREMENTS NOT WITHIN THE LIMITS OUTLINED ABOVE ARE INDICATIVE OF A POTENTIAL SHOCK HAZARD AND MUST BE CORRECTED BEFORE RETURNING THE APPLIANCE TO THE CUSTOMER.

2. PRODUCT SAFETY NOTICE

Many electrical and mechanical parts in the appliance have special safety related characteristics. These are often not evident from visual inspection nor the protection afforded by them necessarily can be obtained by using replacement components rated for voltage, wattage, etc. Replacement parts which have these special safety characteristics are identified in this Service Manual.

Electrical components having such features are identified by marking with a Δ on the schematics and on the parts list in this Service Manual.

The use of a substitute replacement component which does not have the same safety characteristics as the PIONEER recommended replacement one, shown in the parts list in this Service Manual, may create shock, fire, or other hazards.

Product Safety is continuously under review and new instructions are issued from time to time. For the latest information, always consult the current PIONEER Service Manual. A subscription to, or additional copies of, PIONEER Service Manual may be obtained at a nominal charge from PIONEER.

—(FOR EUROPEAN MODEL ONLY)—

VAROITUS!

LAITE SISÄLTÄÄ LASERDIODIN, JOKA LÄHETTÄÄ NÄKYMÄTÖNTÄ, SILMILLE VAARALLISTA INFRAPUNASÄTEILYÄ LAITTEEN SISÄLLÄ ON LASERDIODIN LÄHEISYYDESSÄ KUVAN 1. MUKAINEN VAROITUSMERKKI.



LASER
Kuva 1
Lasersäteilyn
varoitusmerkki

WARNING!

DEVICE INCLUDES LASER DIODE WHICH EMITS INVISIBLE INFRARED RADIATION WHICH IS DANGEROUS TO EYES. THERE IS A WARNING SIGN ACCORDING TO PICTURE 1 INSIDE THE DEVICE CLOSE TO THE LASER DIODE.



LASER
Picture 1
Warning sign for
laser radiation

ADVERSEL:

USYNLIG LASERSTRÅLING VED ÅBNING NÅR SIKKERHEDSAFBRYDERE ER UDE AF FUNKTION UNDGÅ UDSÆTTELSE FOR STRÅLING.

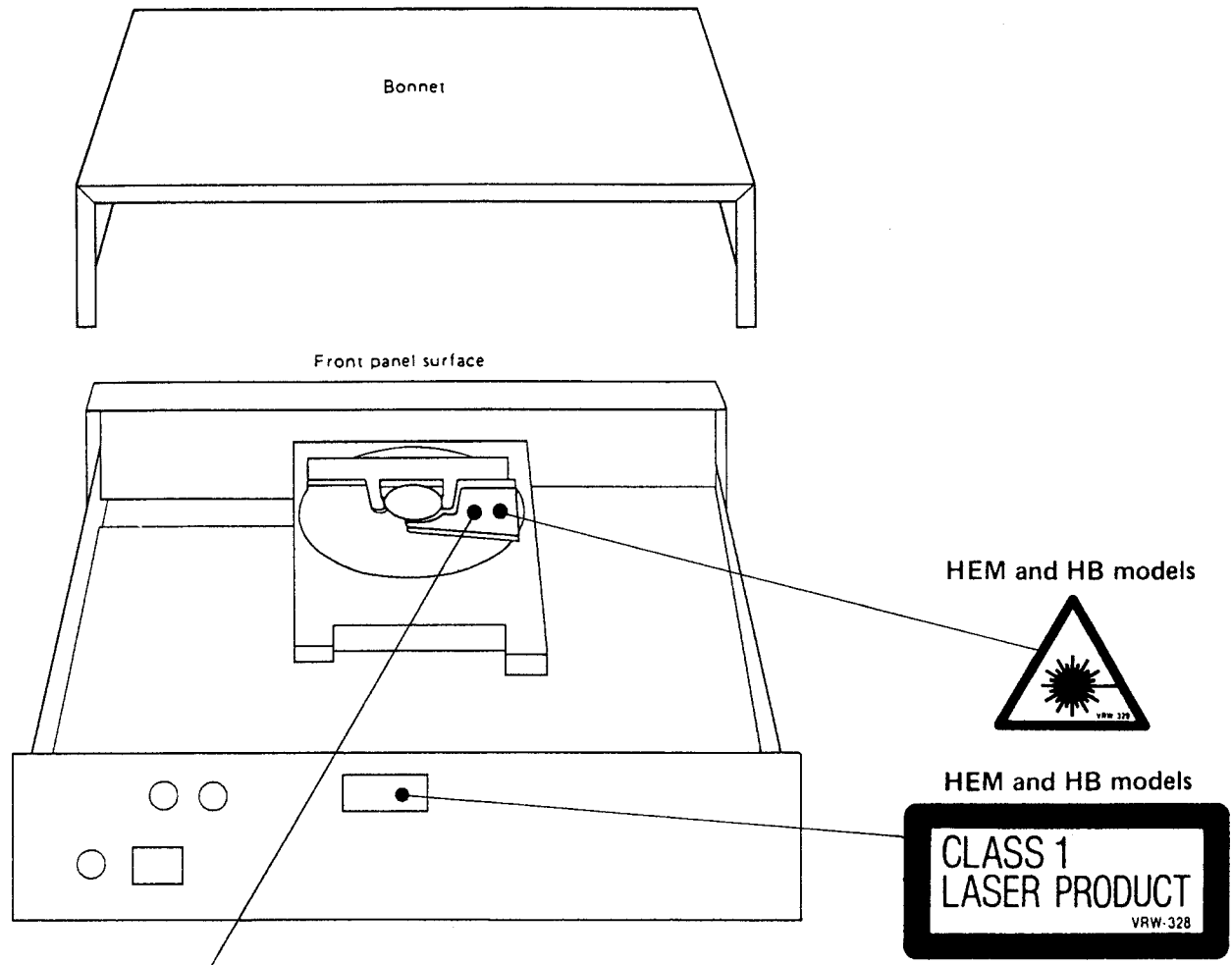
VIKTIGT

APARATEN INNEHÅLLER LASER AV HÖGRE KLASS ÄN 1. INGREPP I APPARATEN BÖR GÖRAS AV SPECIELLT UTBILDAD PERSONAL.

IMPORTANT

THIS PIONEER APPARATUS CONTAINS LASER OF HIGHER CLASS THAN 1. SERVICING OPERATION OF THE APPARATUS SHOULD BE DONE BY A SPECIALLY INSTRUCTED PERSON.

LABEL CHECK



HB model

CAUTION
INVISIBLE LASER
RADIATION WHEN OPEN,
AVOID EXPOSURE
TO BEAM PRW1018

HEM model

CAUTION
LASER RADIATION WHEN OPEN. AVOID EXPOSURE TO BEAM
ADVARSEL
FARE FOR USYNLIG LASERSTRÅLING VED ÅBNING AF DÆKSEL.
UNDGÅ AT UDSÆTTE ØJNE FOR STRÅLING.
VORSICHT!
UNSICHTBARE LASER STRAHLUNG TRIT AUS, WENN DECKEL
ODER KLAPPEI GEÖFFNET IST! NICHT DEM STRAHL AUSSETZEN!
 PRW-175

ADDITIONAL LASER CAUTION

- 1. Laser Interlock Mechanism**
 The ON/OFF status of the clamp switch (S102) for detecting loading completion is detected by the system microprocessor, and the design prevents laser diode oscillation when the clamp switch is OFF.
 Thus, the interlock will no longer function if the clamp switch (S102) is deliberately shorted. In the test mode the interlock mechanism will not function (Refer to page 30).
 Laser diode oscillation will continue if pin 4, 5, or 29 of CXA1081S (IC1) is connected to ground or the terminals of Q1 are shorted to each other (fault condition).
- 2. If the fault condition described in 1 is induced with the cover removed and the objective lens extending past the outer circumference of the disc clamped diameter, close viewing of the objective lens with the naked eye will cause exposure to a Class 1 or higher laser beam.**

2. EXPLODED VIEWS AND PARTS LIST

NOTES :

- Parts without part number cannot be supplied.
- The Δ mark found on some component parts indicates the importance of the safety factor of the part. Therefore, when replacing, be sure to use parts of identical designation.
- Parts marked by "◎" are not always kept in stock. Their delivery time may be longer than usual or they may be unavailable.

2.1 EXTERIOR

Parts List

Mark	No.	Part No.	Description	Mark	No.	Part No.	Description
Δ	1	CM-22C	Strain relief	◎	50	PWZ1499	Sub-function board assembly
Δ	2	PDG1015	AC power cord		51	PNM1078	Cushion
Δ	3	PTT1099	Power transformer (AC120V)		52	PBK1055	Plate spring B
	4	AMR1159	Leg assembly		53	RNH-184	Cord holder
	5	PBA1014	Screw (B)		54	WH40FUC	Washer
	6	PBA1027	Floating screw		55	PNM1079	Tape
	7	PBA1033	SH screw		56	PBM-015	Plastic rivet
	8	PBA1034	Floating screw		57	PBK1054	Plate spring A
	9	PBK1056	Earth plate		58	IBZ30P180FMC	Screw
	10	PEB1109	Stopper rubber		59	PBA1038	Screw
	11	PEB1101	Lose mount rubber		60	VEC-236	Insulator sheet B
	12	AMR1160	LED lens		61	PNM1082	Spacer
	13	PAC1317	Play button		62	PBK1061	Spring plate
	14	PNW1258	Play lens		63	PNM1080	Tape
	15	PAC1318	Number key A		64	PNM1081	Tape
	16	PAC1319	Number key B		65	PNW1238	Wood color
	17	PAC1320	Number key C		66	VBE1003	Washer
	18	PAC1321	Number key D		101		PCB mold
	19	PAC1322	Number key E		102		Top plate
	20	PAC1323	Number key F		103		Spacer
	21	PAC1325	Select button		104		Under base
	22	PAC1326	Power knob		105		Rear base
	23	PAM1290	FL sheet		106		Floating base
	24	PAM1252	Window		107		L angle
	25	PAN1132	Door name plate		108		S angle
	26	PBH1070	Door spring		109		M angle
	27			110		Transformer base
	28	PNW1457	Tray name plate		111		Side angle
	29	PNW1458	Door		112		Switch angle
	30	PNW1459	Function panel		113		Sheet
	31	PNW1460	Lens A		114		Rear shield
	32	PNW1490	Center panel		115		Shield cover
	33	VXA1053	Damper assembly		116		Slide guide
	34	BBZ30P060FCC	Screw		117		Rear cover
	35	BBZ30P080FCC	Screw		118		Mechanism base
	36	BBZ30P100FMC	Screw		119		PCB spacer
	37	BPZ30P250FMC	Screw		120		Loading base assembly
	38	BBT30P080FCU	Screw		121		Tray assembly
	39	IBZ30P080FCC	Screw		122		Servo mechanism assembly
	40	IBZ30P150FCU	Screw		123		Name plate
	41	BBZ40P100FCC	Screw		124		Front panel
	42	PMZ30P060FCU	Screw		125		Plate
	43	IBZ30P100FCC	Screw		126		7 segment spacer
	44	WC30FUC	Washer		127		Primary board assembly
	45	PYY1071	Bonnet		128		Function board assembly
	46	PYY1099	Front panel assembly		129		LED board assembly
◎	47	PWZ1546	Main board assembly		130		Read wire holder
◎	48	PWZ1547	Audio board assembly				
◎	49	PWZ1548	Power supply board assembly				

1

2

3

4

5

6

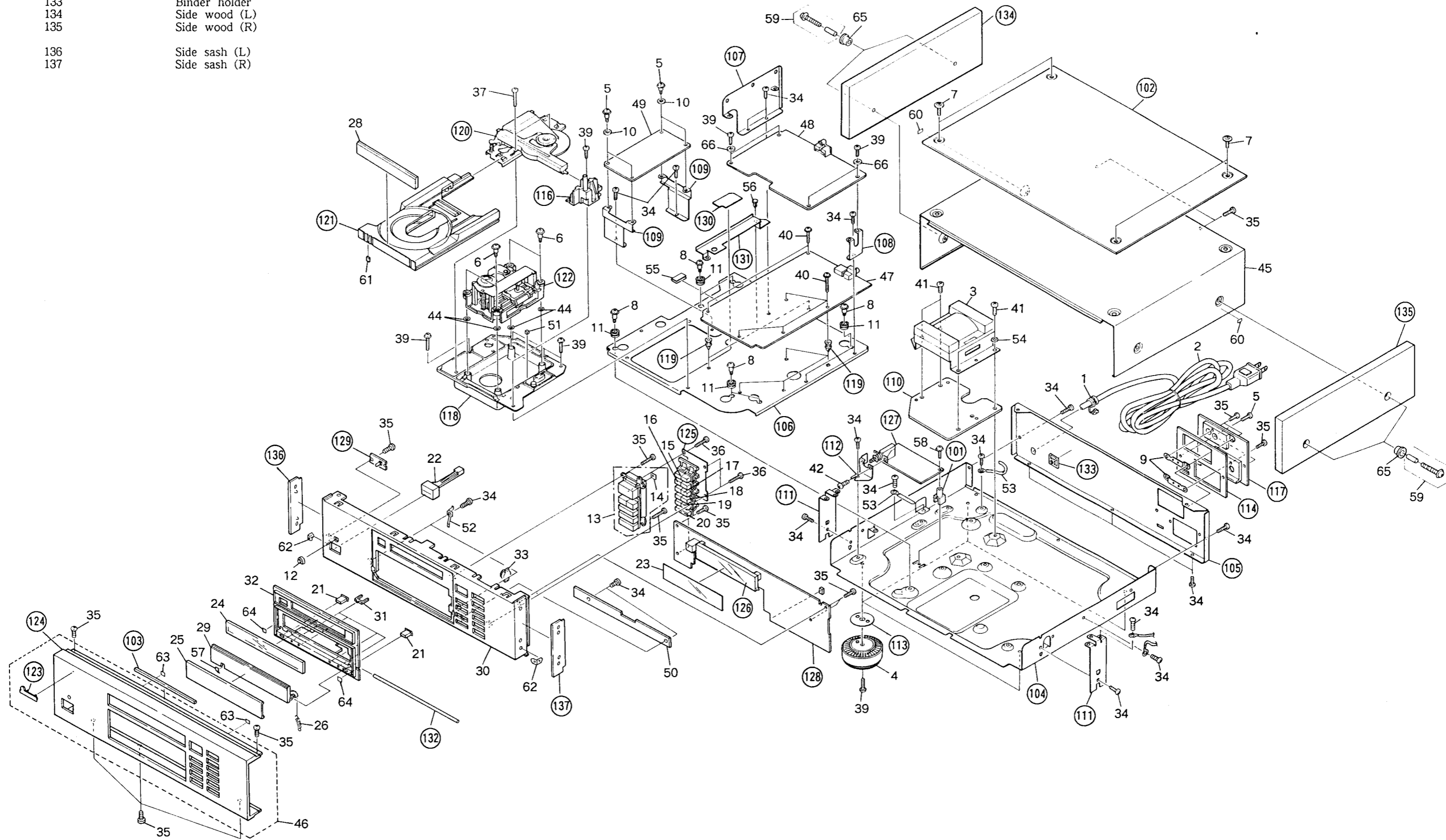
Mark	No.	Part No.	Description
	131		Flexible cord holder
	132		Shaft
	133		Binder holder
	134		Side wood (L)
	135		Side wood (R)
	136		Side sash (L)
	137		Side sash (R)

A

B

C

D



A

B

C

D

1

2

3

4

5

6

6

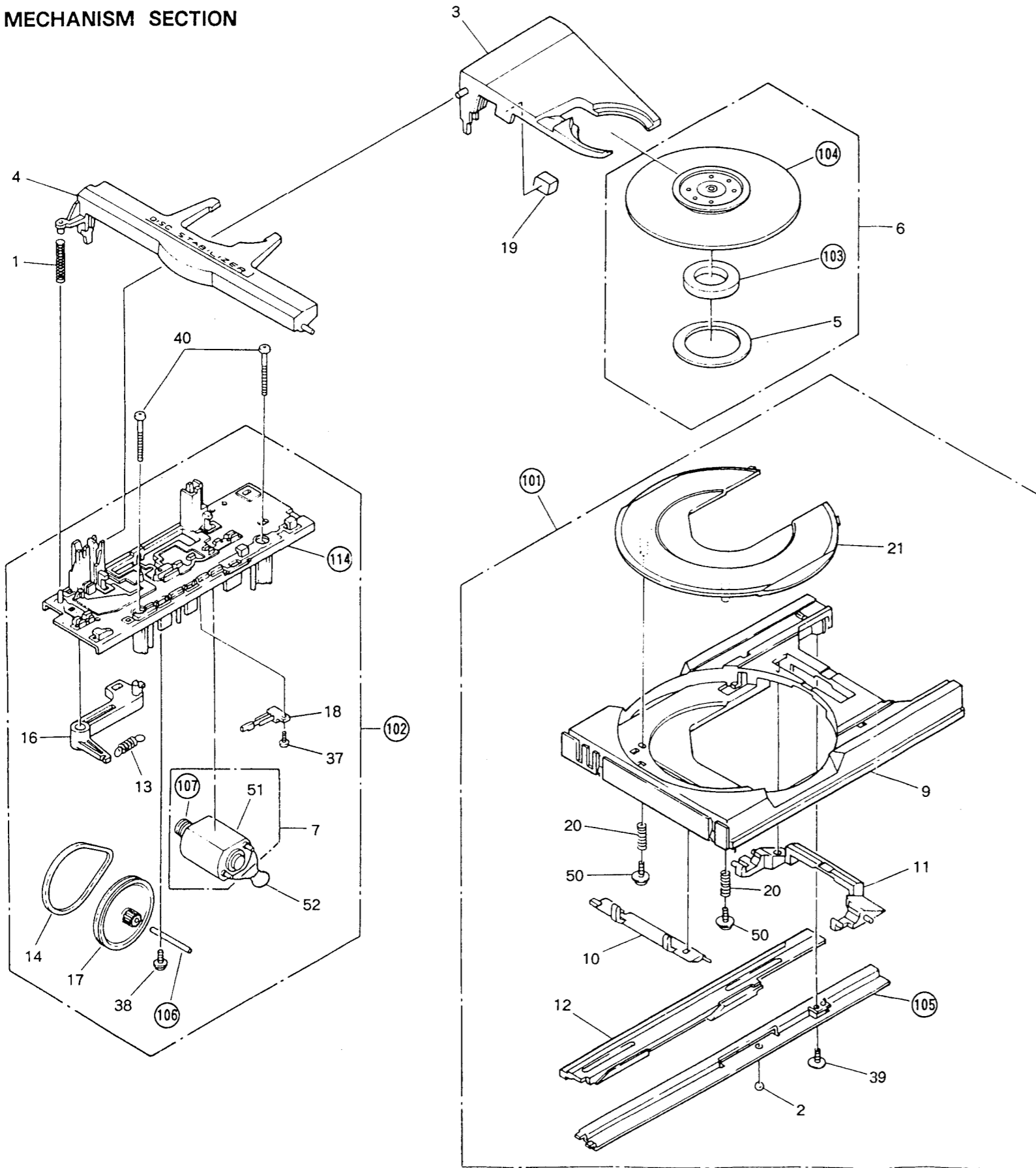
2.2 MECHANISM SECTION

A

B

C

D

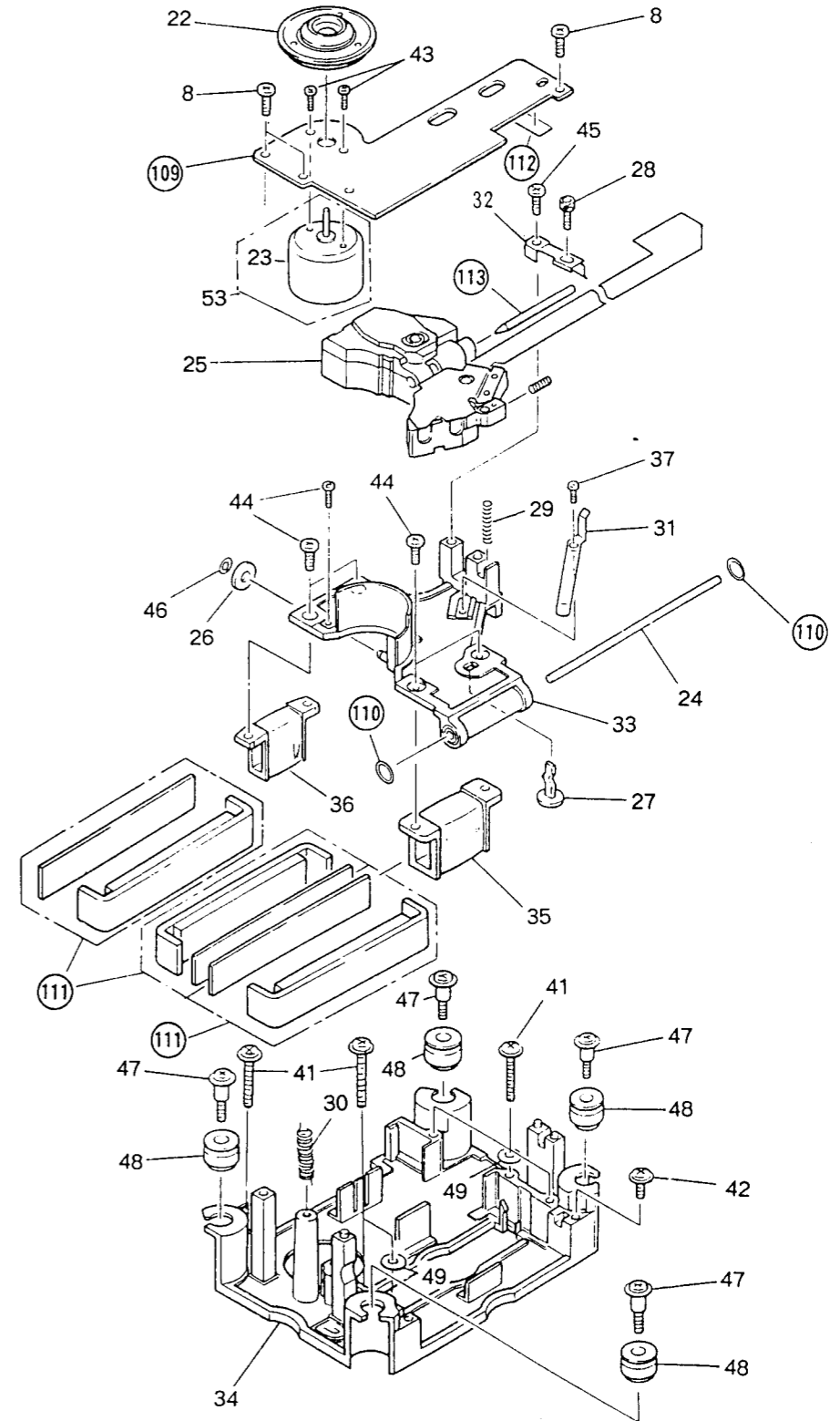


A

B

C

D



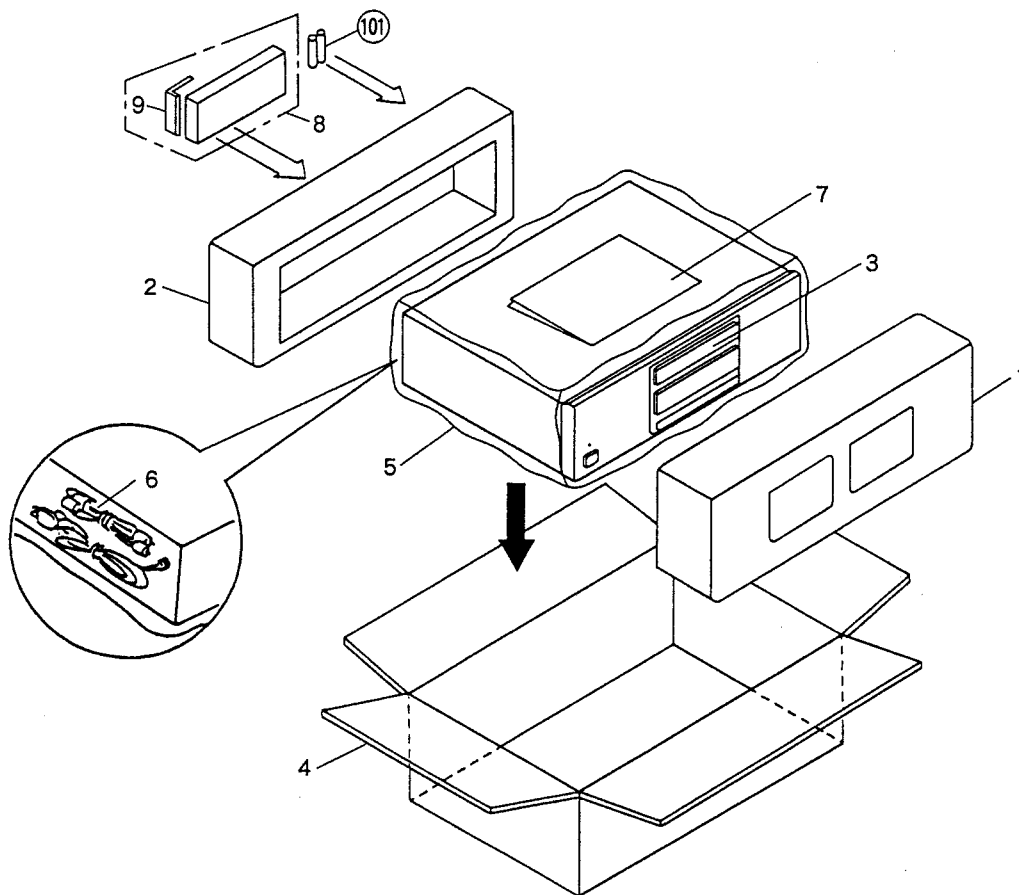
Parts List of Mechanism Section

Mark	No.	Part No.	Description	Mark	No.	Part No.	Description
	1	PBH1013	Spring		101		Tray assembly
	2	PBP-001	Steel ball ϕ 4		102		Loading base assembly
	3	PNW1084	Clamp holder		103		Magnet
	4	PNW1085	Clmap retainer		104		Clamper
	5	PNM1010	Disc cushion		105		Slide base
	6	PYY1084	Clamper assembly		106		Gear shaft
	7	PYY1025	Motor assembly (LOADING)		107		Motor pully
	8	PBA1031	Screw (2 \times 8)		108	
	9	PNW1390	Tray		109		Base plate
	10	PNW1330	Plate lever (F)		110		Rubber ring
	11	PNW1331	Plate lever (R)		111		Yoke unit
	12	PNW1332	Rack		112		Felt
	13	PBH1012	Clamper spring		113		PU guide bar
	14	PEB1013	Belt		114		Loading base
	15					
	16	PNW1083	Clamper lever				
	17	PNW1171	Gear pully				
	18	VSK-015	Leaf switch (CLAMP : S102)				
	19	PEB1032	Stopper rubber				
	20	PBH1045	Plate spring				
	21	PNW1329	Disc plate				
	22	PNW1526	Disc table				
	23	PXM1009	Spindle motor				
	24	PLA1061	Guide bar				
	25	PWY1006	Pickup assembly				
	26	PNW1408	Roller				
	27	PNW1407	Adjustment shaft				
	28	PBA1026	Adjustment screw				
	29	PBH1029	Shaft spring				
	30	PBH1068	Earth spring				
	31	PBK1045	Plate spring T				
	32	PBK1046	Plate spring R				
	33	PNW1405	Carriage				
	34	PNW1406	Mechanism chassis				
	35	PXP1001	Drive unit				
	36	PXP1002	Detector unit				
	37	BPZ20P080FZK	Screw				
	38	IPZ30P060FMC	Screw				
	39	PPZ30P080FMC	Screw				
	40	BBZ30P250FMC	Screw				
	41	IBZ30P180FMC	Screw				
	42	IPZ30P080FMC	Screw				
	43	PMZ20P030FMC	Screw				
	44	PMZ26P040FMC	Screw				
	45	PPZ26P080FMC	Screw				
	46	WT25D047D025	Washer				
	47	PBA1027	Floating screw				
	48	PEB1031	Floating rubber				
	49	WA32F100M050	Washer				
	50	PBA1025	Screw				
	51	PXM1002	Motor (LOADING)				
	52	CKDYF103Z50	Ceramic capacitor				
	53	PYY1110	Motor assembly (Spindle with oil)				

3. PACKING

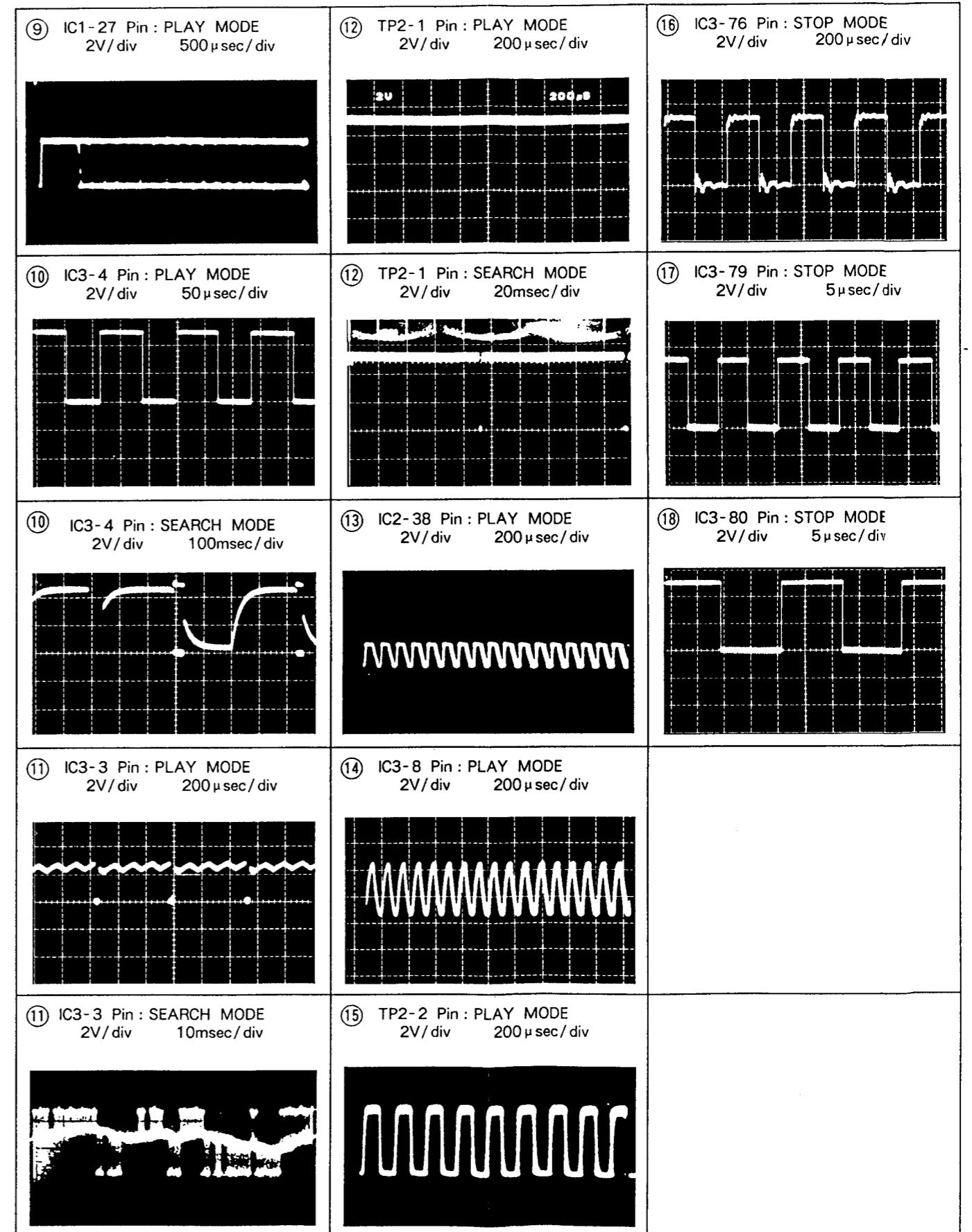
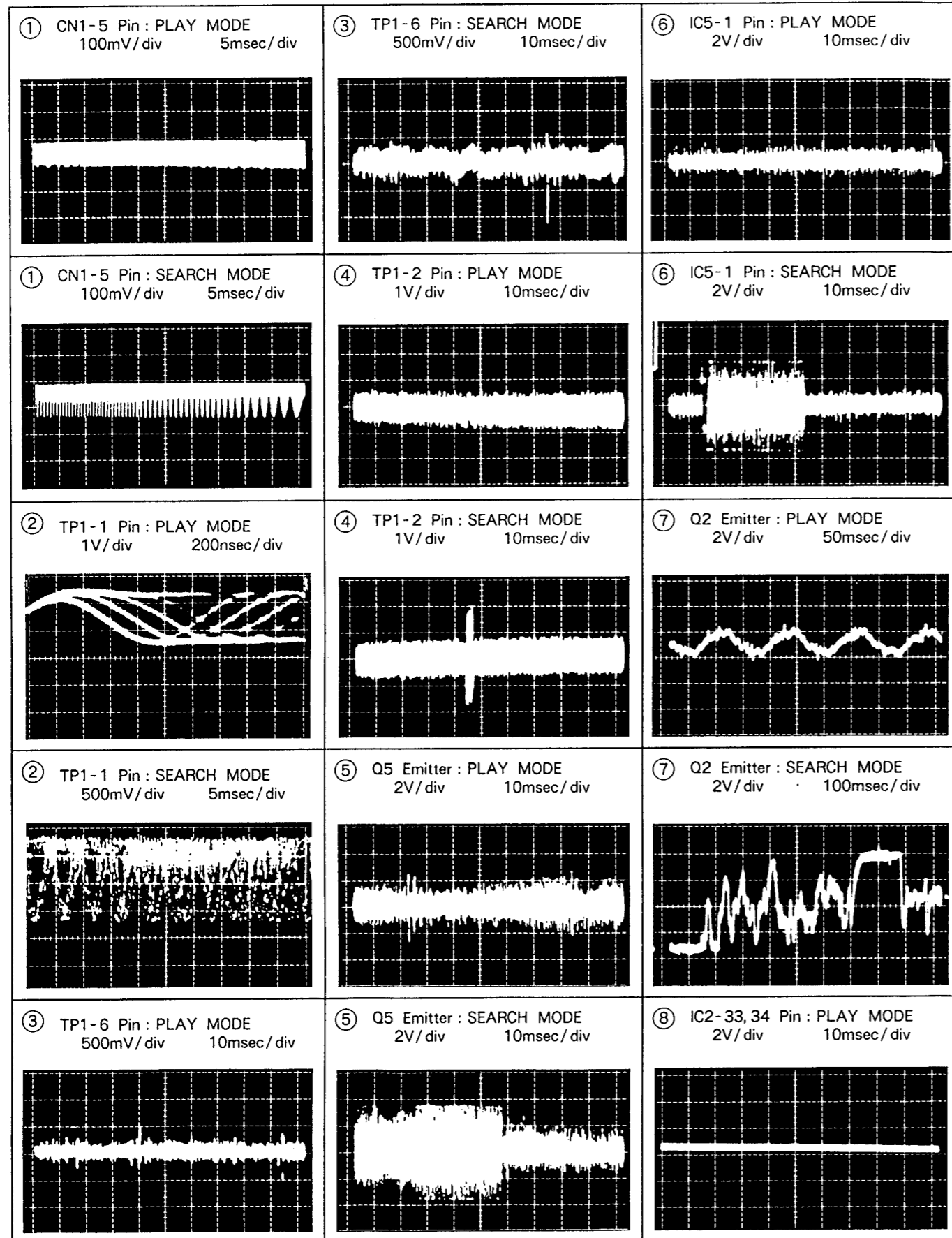
Parts List

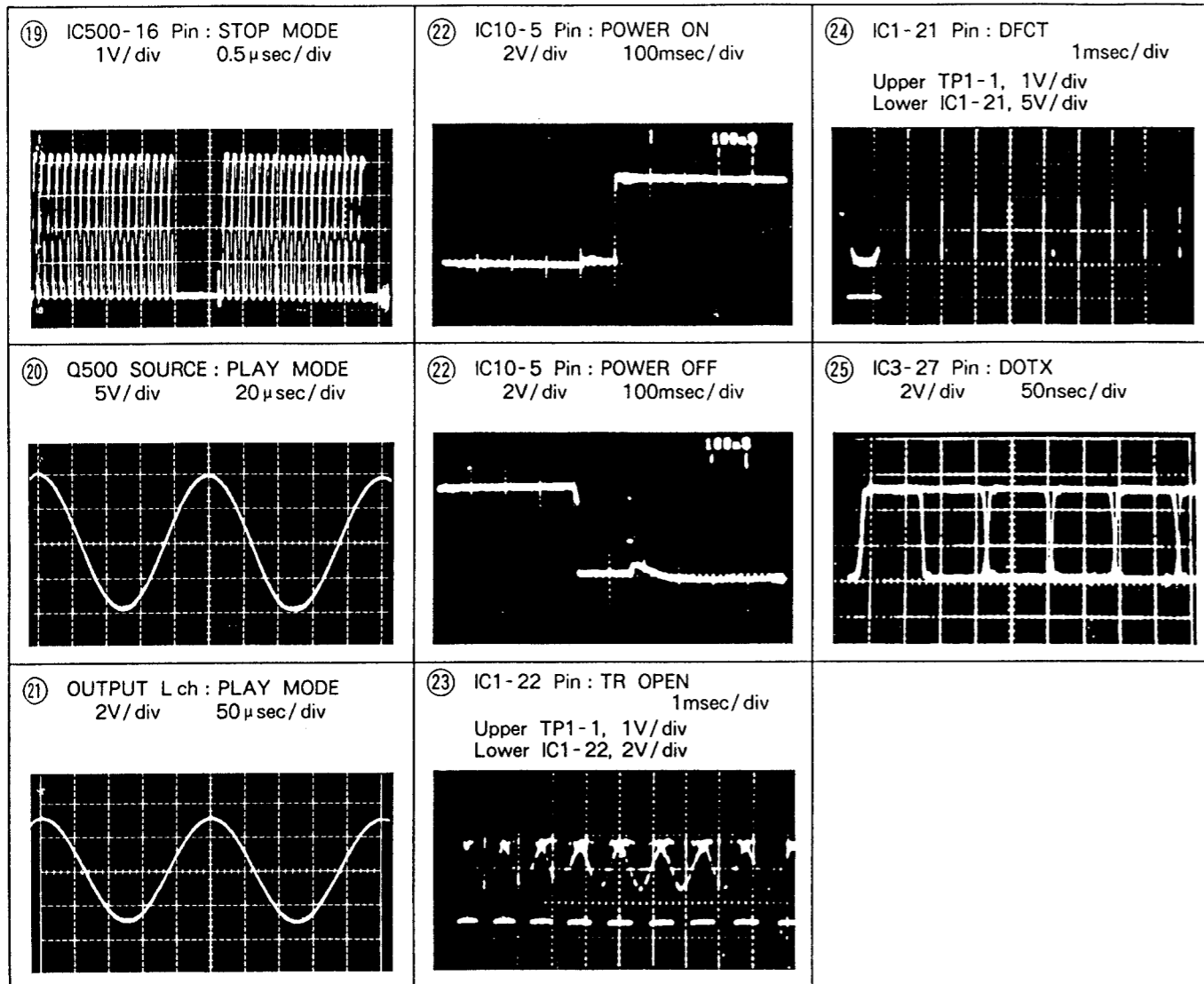
Mark	No.	Part No.	Description
	1	PHA1095	Protector (F)
	2	PHA1096	Protector (R)
	3	PHC1030	Spacer (into the tray)
	4	PHG1308	CD packing case
	5	VHL-037	Sheet
	6	PDE1003	Connection cord with pin plug
	7	PRB1085	Operating instructions (English)
	8	PWW1037	Remote control unit
	9	PNW1153	Battery cover
101			Battery



WAVE FORMS

NOTE: The encircled numbers denote measuring points in the schematic diagram.





4. SCHEMATIC DIAGRAM

1. RESISTORS :
Indicated in Ω , 1/4W, 1/6W and 1/8W, $\pm 5\%$ tolerance unless otherwise noted k ; k Ω , M ; M Ω , (F) ; $\pm 1\%$, (G) ; $\pm 2\%$, (K) ; $\pm 10\%$, (M) ; $\pm 20\%$ tolerance.
2. CAPACITORS :
Indicated in capacity (μF) /voltage (V) unless otherwise noted p ; pF. Indication without voltage is 50V except electrolytic capacitor.
3. VOLTAGE, CURRENT :
 - \square ; DC voltage (V) at play state.
 - \Leftarrow mA ; DC current at play state.
 - Value in () is DC current at stop state.
4. OTHERS :
 - \rightarrow ; Signal route.
 - \otimes ; Adjusting point.

The Δ mark found on some component parts indicates the importance of the safety factor of the part. Therefore, when replacing, be sure to use parts of identical designation.
 \ast marked capacitors and resistors have parts numbers.

This is the basic schematic diagram, but the actual circuit may vary due to improvements in design.

5. SWITCHES : (The underlined indicates the switch position)

- MAIN BOARD ASSEMBLY
- S1 : TEST MODE
- FUNCTION BOARD ASSEMBLY
- S201 : 1
- S202 : 2
- S203 : 3
- S204 : 4
- S205 : 5
- S206 : 6 TRACK No. KEY
- S207 : 7
- S208 : 8
- S209 : 9
- S210 : 10
- S211 : + 10
- S212 : ≥ 20
- S213 : $\blacktriangleright\blacktriangleright$] TRACK SEARCH
- S214 : $\blacktriangleleft\blacktriangleleft$]
- S233 : PAUSE (||)
- S234 : PLAY (\triangleright)
- S235 : OPEN/CLOSE (\blacktriangle)
- S236 : STOP (\blacksquare)
- SUB - FUNCTION BOARD ASSEMBLY
- S801 : OUTPUT SELECTOR DIGITAL - ANALOG
- S802 : DISPLAY OFF ON/OFF
- PRIMARY BOARD ASSEMBLY
- S301 : POWER ON - OFF
- OUTSIDE OF P. C. BOARDS ASSEMBLY
- S102 : CLAMP CLAMP - OPEN

A

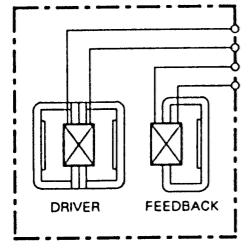
B

C

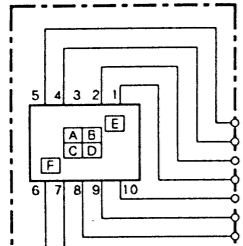
D

5. P. C. BOARDS CONNECTION DIAGRAM

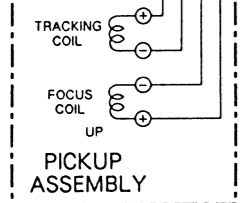
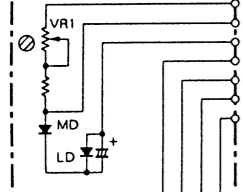
A



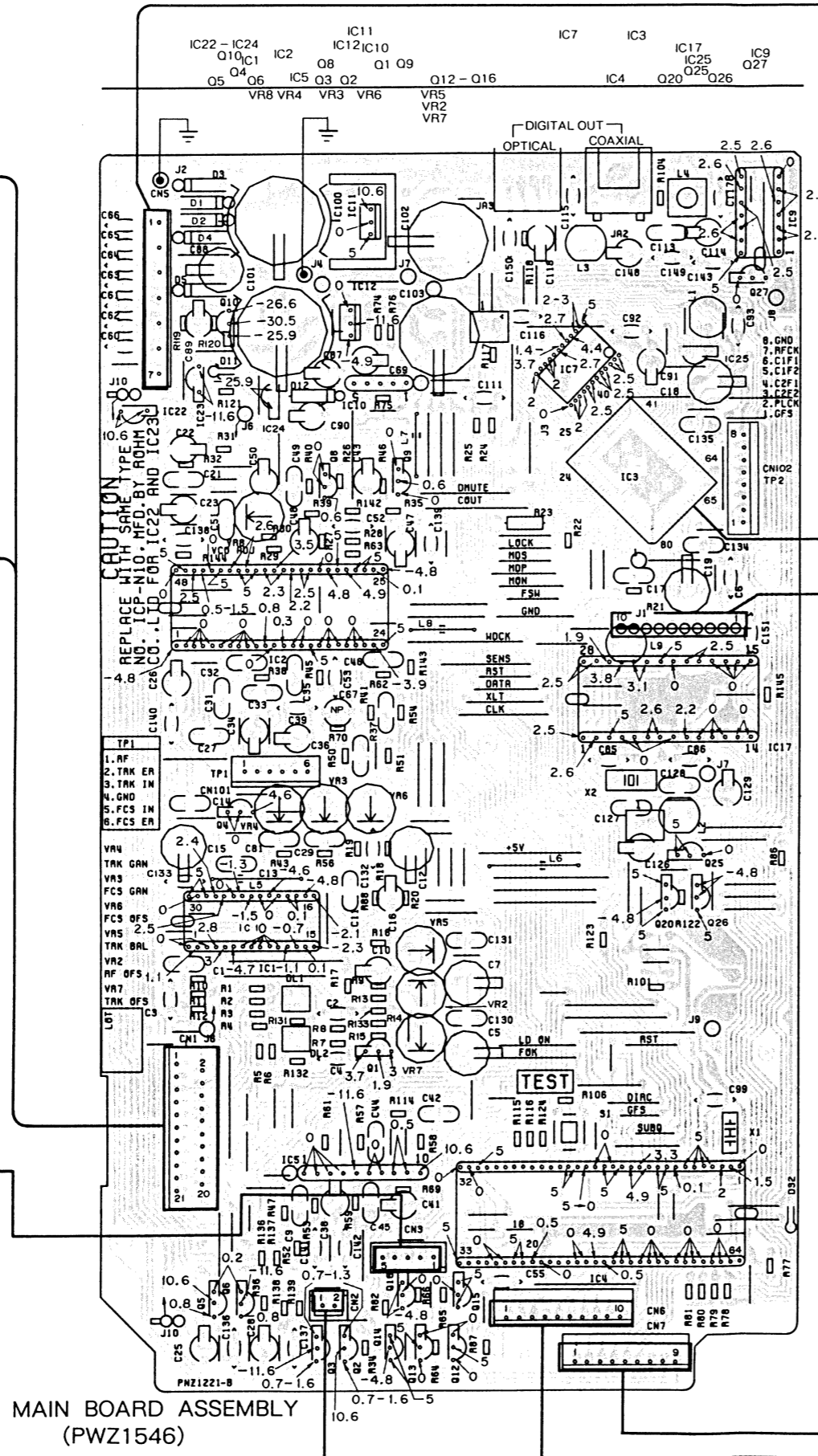
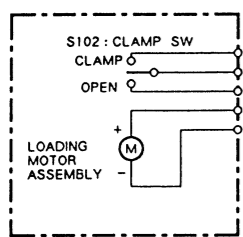
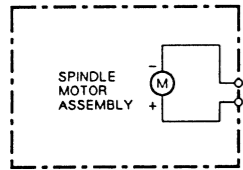
B



C



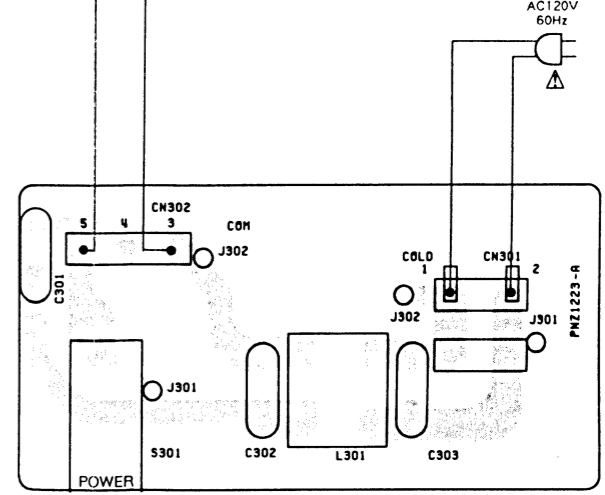
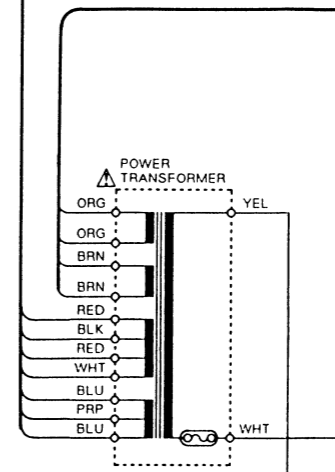
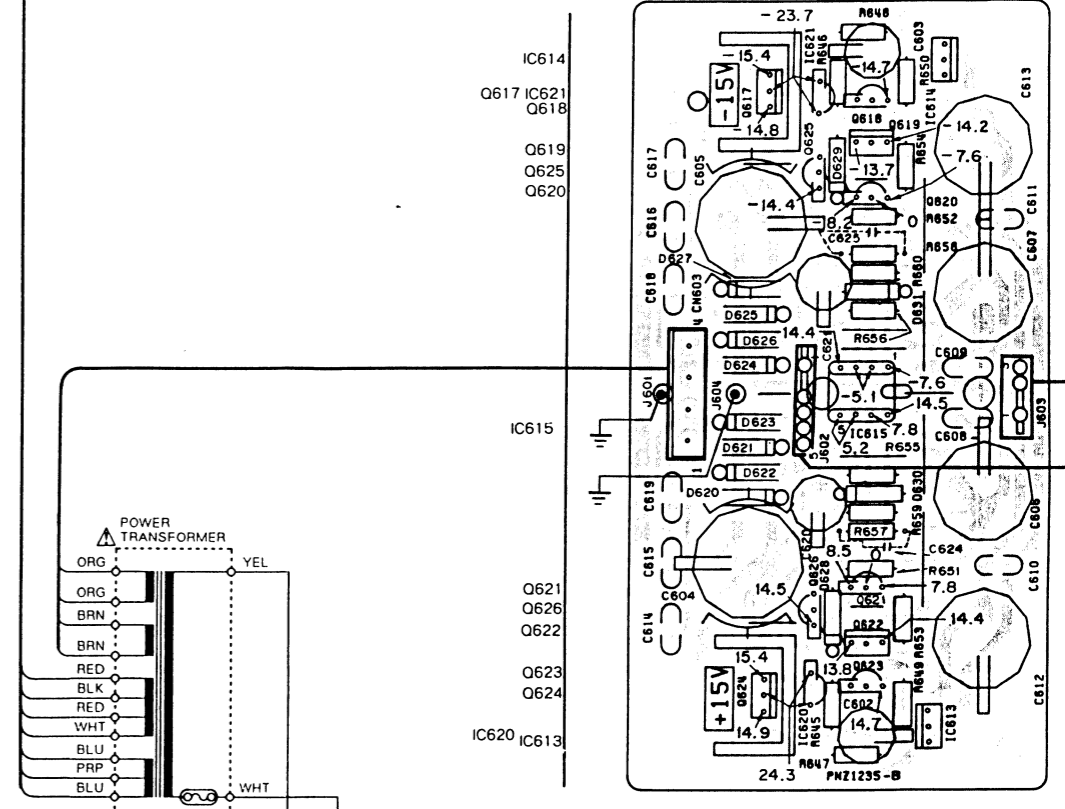
D



MAIN BOARD ASSEMBLY (PWZ1546)

Pin No.	Volts	Pin No.	Volts
1	0	41	2.5
2	0	42	2.5
3	2.6	43	2.5
4	2.8	44	2.5
5	2.4	45	2.5
6	2.5	46	2.0-3.0
7	5.0	47	2.0-3.0
8	2.4	48	1.5-3.7
9	2.4	49	4.4
10	0	50	2.7
11	1.5	51	NC
12	0	52	0
13	4.8	53	2.3
14	5.0	54	NC
15	4.9	55	0
16	5.0	56	0.6
17	0.1	57	5.0
18	5.0	58	0
19	0	59	0
20	NC	60	NC
21	0	61	NC
22	0.1	62	0
23	2.7-3.5	63	0
24	0.1	64	0
25	4.8	65	0
26	5.0	66	NC
27	2.4	67	NC
28	5.0	68	2.5
29	2.0	69	2.5
30	2.0	70	2.4
31	2.0	71	NC
32	2.0	72	NC
33	5.0	73	5.0
34	2.0	74	NC
35	2.0	75	NC
36	2.0	76	2.5
37	2.0	77	NC
38	2.5	78	2.5
39	2.5	79	2.5
40	2.5	80	2.5

POWER SUPPLY BOARD ASSEMBLY (PWZ1548)



PRIMARY BOARD ASSEMBLY

LED ASSE

1

2

3

4

5

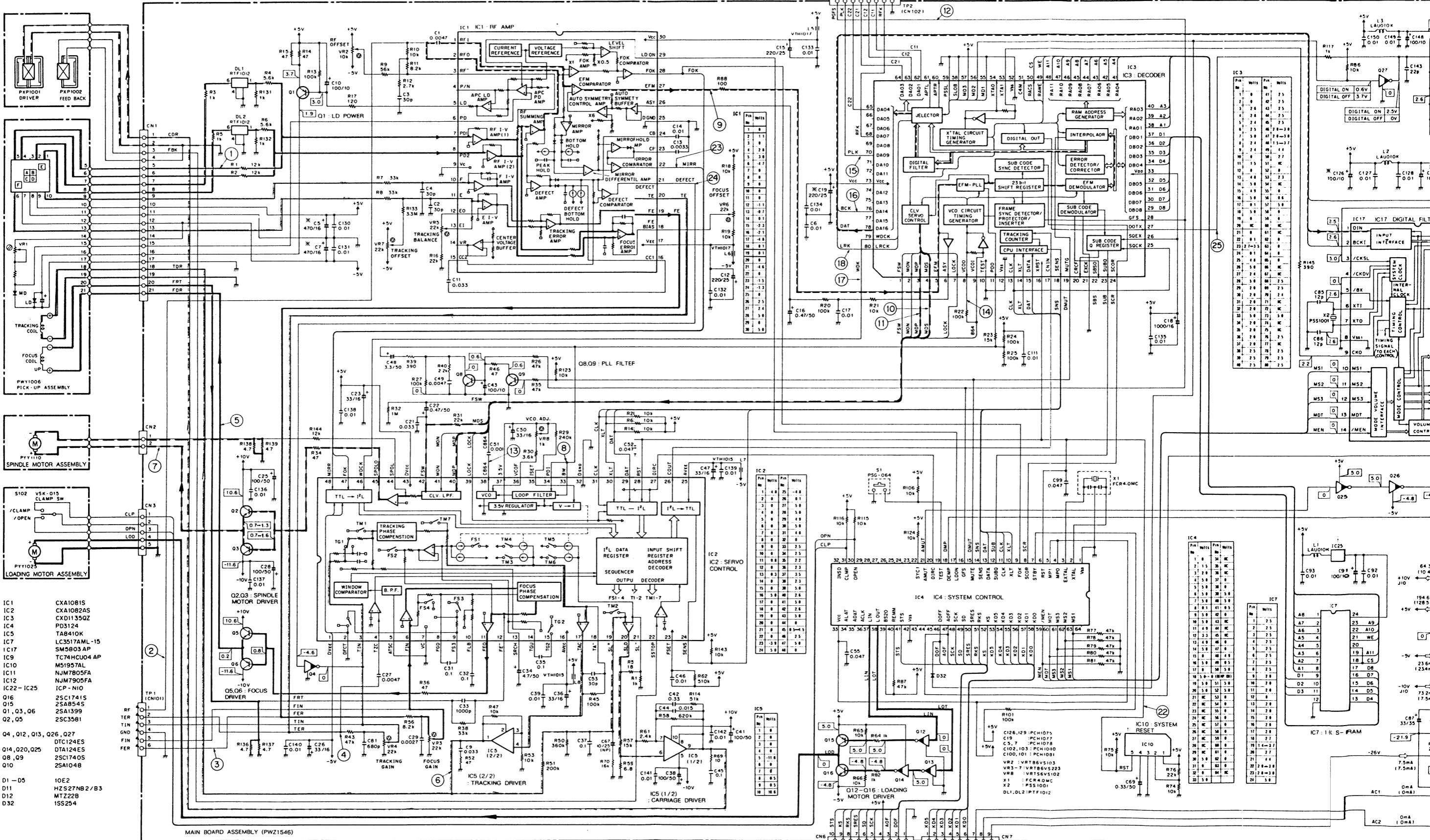
6

A

B

C

D



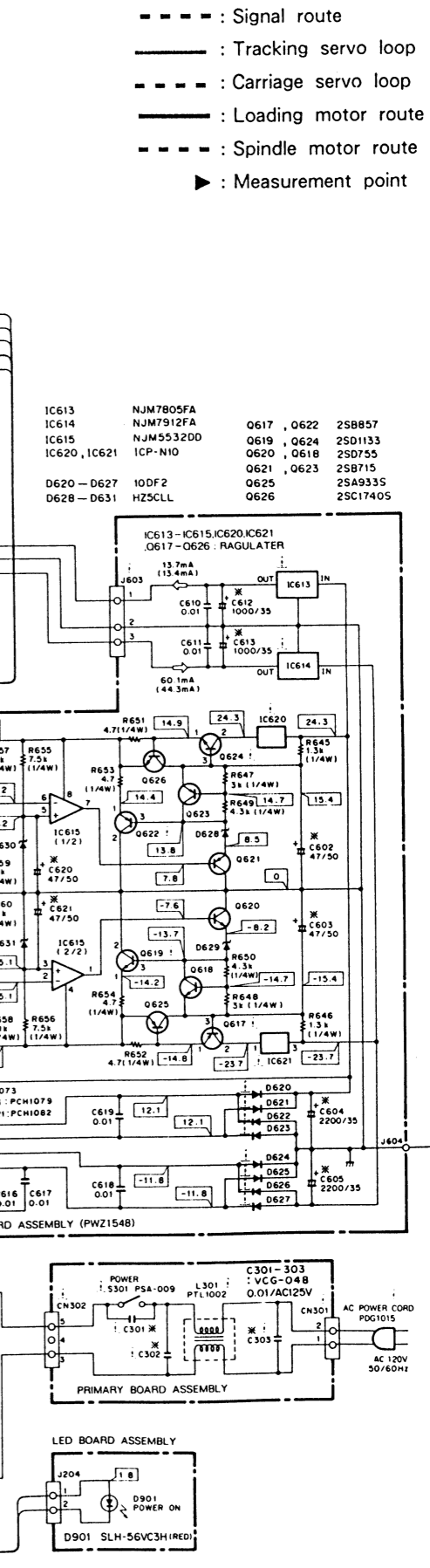
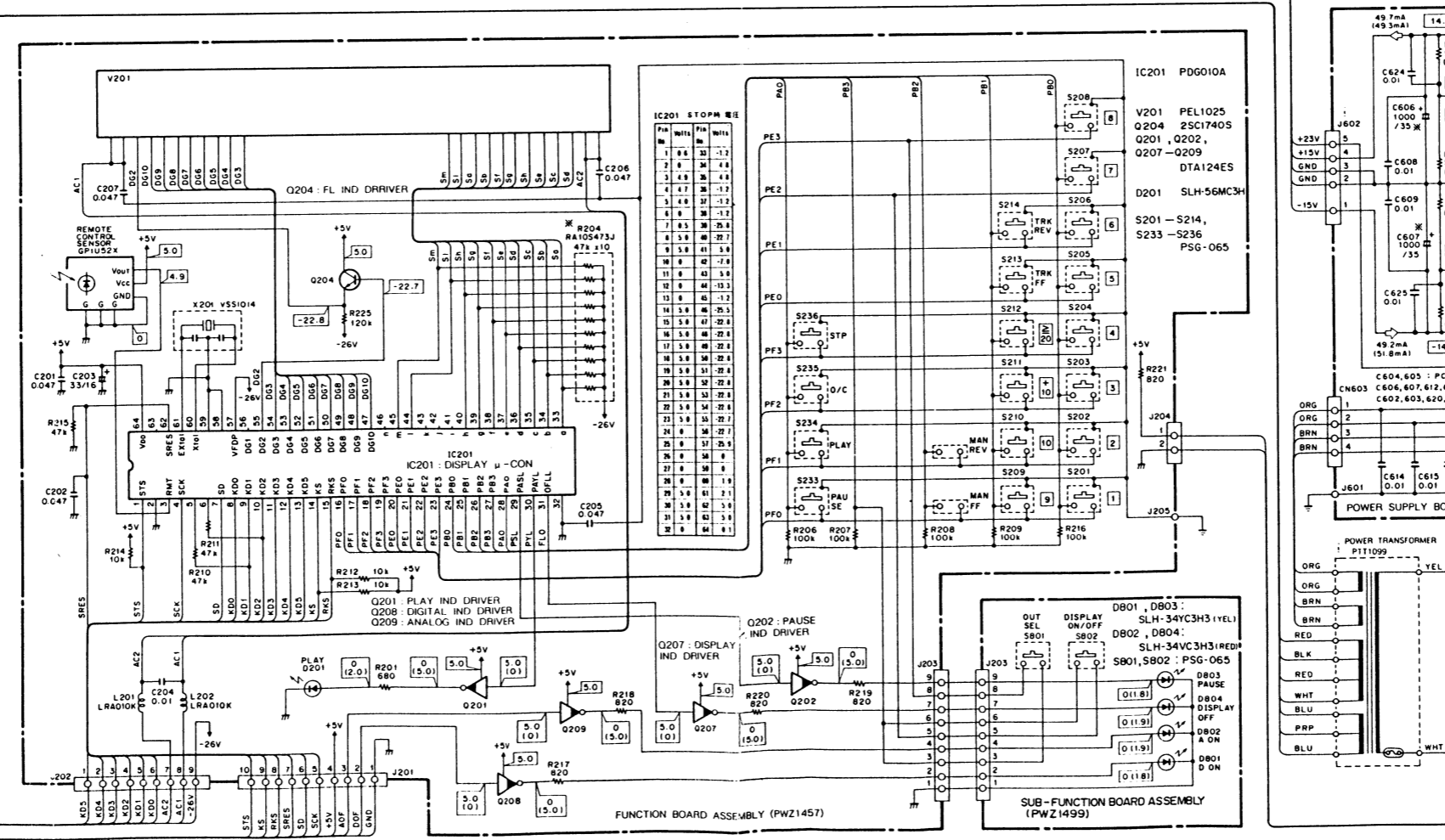
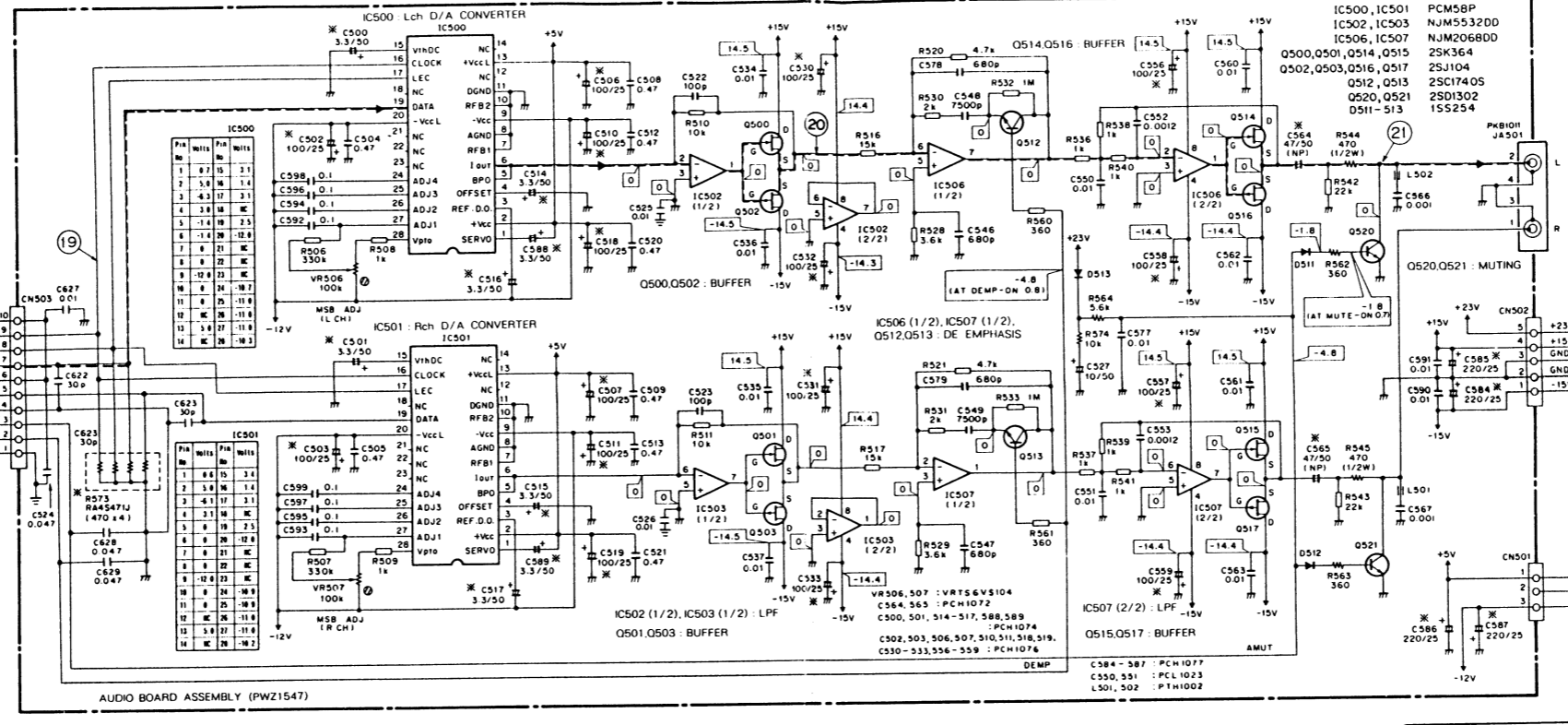
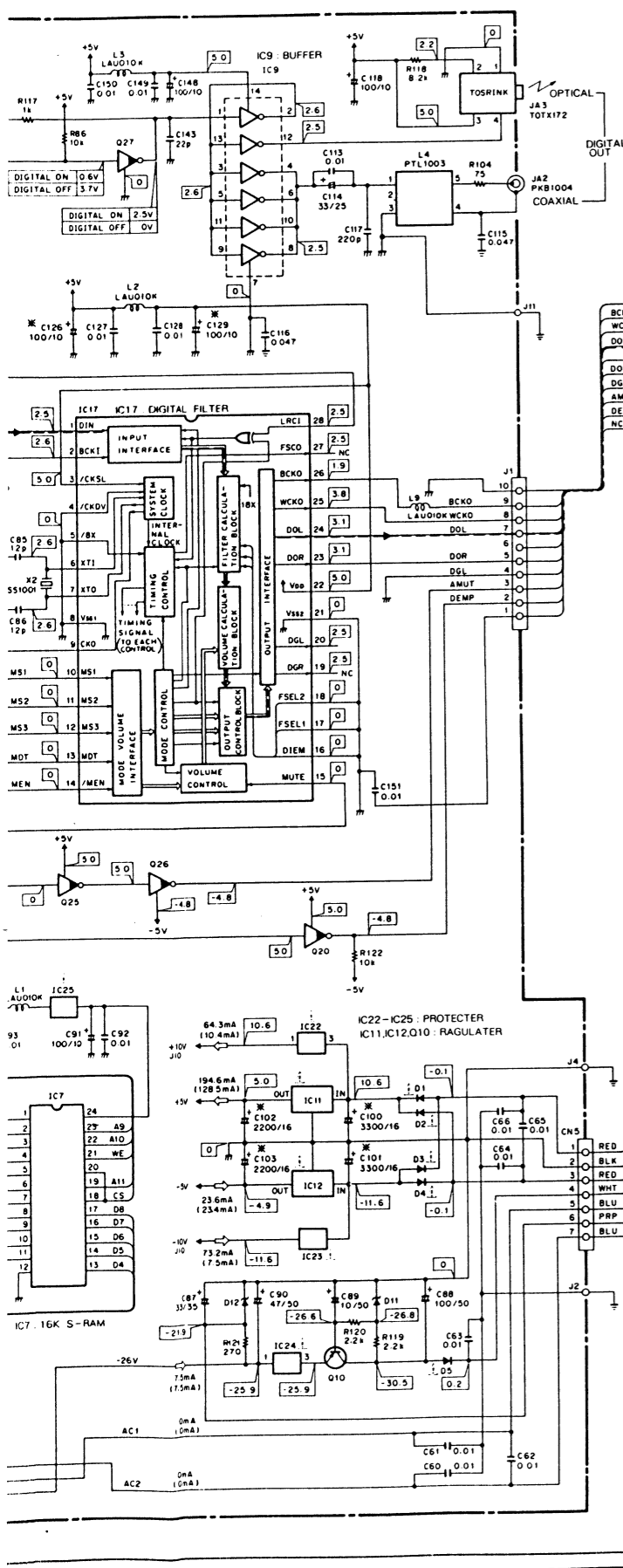
- : Focus servo loop
- - - : Signal route
- : Tracking servo loop
- - - : Carriage servo loop
- : Loading motor route
- - - : Spindle motor route
- ▶ : Measurement point

A

B

C

D



6. ELECTRICAL PARTS LIST

NOTES :

- Parts without part number cannot be supplied.
- Parts marked by "⊙" are not always kept in stock. Their delivery time may be longer than usual or they may be unavailable.
- The Δ mark found on some component parts indicates the importance of the safety factor of the part. Therefore, when replacing, be sure to use parts of identical designation.
- When ordering resistors, first convert resistance values into code form as shown in the following examples.

Ex.1 When there are 2 effective digits (any digit apart from 0), such as 560 ohm and 47k ohm (tolerance is shown by J = 5 %, and K = 10 %).

560 Ω → 56 × 10¹ → 561..... RD1/4PS 561J
 47k Ω → 47 × 10³ → 473..... RD1/4PS 473J
 0.5 Ω → 0R5 RN2H 0R5K
 1 Ω → 010..... RS1P 010K

Ex.2 When there are 3 effective digits (such as in high precision metal film resistors).

5.62k Ω → 562 × 10¹ → 5621..... RN1/4SR 5621F

Miscellaneous Parts

Mark	Symbol & Description	Part No.
⊙	Sub-function board assembly LED assembly	PWZ1499
⊙	Main board assembly Function board assembly	PWZ1546
⊙	Audio board assembly	PWZ1547
⊙	Power supply board assembly Primary board assembly	PWZ1548
Δ	Strain relief	CM-22C
Δ	AC power cord	PDG1015
Δ	Power transformer Pickup assembly Motor assembly (spindle with oil)	PTT1099 PWY1006 PYY1110
	Spindle motor	PXM1009
	Motor assembly (LOADING)	PYY1025
	S102 Leaf switch (CLAMP)	VSK-015
	Remote control unit	PNW1153

⊙ Sub-Function Board Assembly (PWZ1499)

SEMICONDUCTORS

Mark	Symbol & Description	Part No.
	D802,D804	SLH-34VC3H3
	D801,D803	SLH-34YC3H3

SWITCHES

Mark	Symbol & Description	Part No.
	S801,S802 Tact switch (OUTPUT SELECTOR, DISPLAY)	PSG-065

LED Board Assembly

SEMICONDUCTOR

Mark	Symbol & Description	Part No.
	D901	SLH-56VC3H

⊙ Main Board Assembly (PWZ1546)

SEMICONDUCTORS

Mark	Symbol & Description	Part No.
	IC1	CXA1081S
	IC2	CXA1082AS
	IC3	CXD1135QZ
Δ	IC22 - IC25	ICP-N10
	IC7	LC3517AML-15
Δ	IC10	M51957AL
Δ	IC11	NJM7805FA
Δ	IC12	NJM7905FA
	IC4	PD3124
	IC17	SM5803AP
Δ	IC5	TA8410K
	IC9	TC74HCU04AP
	Q14,Q20,Q25	DTA124ES
	Q4,Q12,Q13,Q26,Q27	DTC124ES
	Q10	2SA1048
	Q1,Q3,Q6	2SA1399
	Q15	2SA854S
	Q16	2SC1741S
	Q8,Q9	2SC1740S
	Q2,Q5	2SC3581
	D11	HZS27NB2
	D12	MTZ22B
	D32	1SS254
Δ	D1 - D5	10E2

SWITCH

Mark	Symbol & Description	Part No.
	S1 Tact switch (TEST MODE)	PSG-064

COILS

Mark	Symbol & Description	Part No.
	L1 - L3,L9	LAU010K
	L4 Pulse transformer	PTL1003
	L5,L6 Ferrite bead	VTH1017
	L7,L8 Ferrite bead	VTH1015

CAPACITORS

Mark	Symbol & Description	Part No.
C85,C86		CCCCH120J50
C2 - C4,C53		CCCCH300J50
C143		CCCSL220J50
C117		CCCSL471J50
C67		CEANP100M25
C69		CEASR33M50
C16,C22		CEASR47M50
C89		CEAS100M50
C10,C43,C91,C118,C148		CEAS101M10
C25,C28,C38,C41,C88		CEAS101M50
C18		CEAS102M16
C12,C15		CEAS221M25
C48		CEAS3R3M50
C23,C26,C47,C50		CEAS330M16
C87		CEAS330M35
C34		CEAS4R7M50
C90		CEAS470M50
C114		CEYA330M25
C33,C51		CFTXA102J50
C14,C17,C46,C113,C127, C128,C130,C131,C134,C135		CFTXA103J50
C31,C32,C35,C37,C45		CFTXA104J50
C44		CFTXA153J50
C29		CFTXA272J50
C13		CFTXA332J50
C9,C11,C21		CFTXA333J50
C42		CFTXA334J50
C1,C27,C49		CFTXA472J50
C81		CFTXA681J50
C6,C39,C60 - C66,C92,C93, C111,C132,C133,C136 - C142, C149 - C151		CKCYF103Z50
C120		CKCYF473Z50
C52,C55,C99,C115,C116		PCH1075
C126,C129 (100 μ F/10V)		PCH1077
C19 (220 μ F/250V)		PCH1078
C5,C7 (470 μ F/16V)		
C102,C103 (220 μ F/16V)		PCH1080
C100,C101 (3300 μ F/16V)		PCH1081

RESISTORS

Mark	Symbol & Description	Part No.
VR2	Semi-fixed (10k Ω)	VRTB6VS103
VR3 - VR7	Semi-fixed (22k Ω)	VRTB6VS223
VR8	Semi-fixed (1k Ω)	VRTS6VS102
R23		RD1/4PM153J
R30	Metal thin film	RN1/6PQ3601F
R14,R15,R47,R52,R53, R136 - R139		RDR1/2PM□□□J
Other resistors		RD1/6PM□□□J

OTHERS

Mark	Symbol & Description	Part No.
JA2	1P Pin jack (DIGITAL)	PKB1004
X1	Ceramic resonator	FCR4.0MC
X2	Crystal resonator	PSS1001
DL1,DL2	Delay line	PTF1012
JA3	Optical digital output terminal	TOTX172

Function Board Assembly

SEMICONDUCTORS

Mark	Symbol & Description	Part No.
IC201		PDG010A
Q201,Q202,Q207 - Q209		DTA124ES
Q204		2SC1740S
D201		SLH-56MC3H

SWITCHES

Mark	Symbol & Description	Part No.
S201 - S214,S233 - S236	Tact switch (TRACK No. KEY (1 - 10, + 10, ≥ 20), TRACK SEARCH (◀◀, ▶▶), PAUSE (), PALY (▶), OPEN/CLOSE (▲), STOP (■))	PSG-065

COILS

Mark	Symbol & Description	Part No.
L201,L202		LRA010K

CAPACITORS

Mark	Symbol & Description	Part No.
C203		CEAS330M16
C204		CKCYF103Z50
C201,C202,C205 - C207		CKCYF473Z50

RESISTORS

Mark	Symbol & Description	Part No.
R204		RA10S473J
Other resistors		RD1/6PM□□□J

OTHERS

Mark	Symbol & Description	Part No.
V201	Fluorescent indicator tube	PEL1025
X201	Ceramic resonator	VSS1014
	Remote control sensor	GP1U52X

◎ Audio Board Assembly (PWZ1547)

SEMICONDUCTORS

Mark	Symbol & Description	Part No.
	IC502,IC503	NJM5532DD
	IC506,IC507	NJM2068DD
	IC500,IC501	PCM58P-K
	Q512,Q513	2SC1740S
	Q520,Q521	2SD1302
	Q502,Q503,Q516,Q517	2SJ104
	Q500,Q501,Q514,Q515	2SK364
	D511 - D513	1SS254

CAPACITORS

Mark	Symbol & Description	Part No.
	C550,C551 (0.01 μ F)	PCL1023
	C564,C565 (47 μ F/50V)	PCH1072
	C500,C501,C514 - C517,C588,	PCH1074
	C589 (3.3 μ F/50V)	
	C502,C503,C506,C507,C510,	PCH1076
	C511,C518,C519,C530 - C533,	
	C556 - C559 (100 μ F/25V)	
	C584 - C587 (220 μ F/25V)	PCH1077
	C622,C623	CCCCH300J50
	C527	CEAS100M50
	C504,C505,C508,C509,C512,	CFTXA474J50
	C513,C520,C521	
	C534 - C537,C560 - C563,C577,	CFTXA103J50
	C590,C591	
	C592 - C599	CFTXA104J50
	C525,C526	CKCYF103Z50
	C548,C549	CQPYA752J2A
	C524	CKCYF473Z50
	C522,C523	CQSF101J50
	C566,C567	CQSF102J50
	C552,C553	CQSF122J50
	C546,C547,C578,C579	CQSF681J50
	C627	CKDYF103Z50
	C628,C629	CKDYF473Z50

COILS

Mark	Symbol & Description	Part No.
	L501,L502 Ferrite bead	PTH1002

RESISTORS

Mark	Symbol & Description	Part No.
	VR506,VR507 Semi-fixed (100k Ω)	VRTS6VS104
	R573 Resistor array	RA4S471J
	R544,R545	RD1/2PM471J
	R562 - R564,R574	RD1/6PM□□□J
	R536 - R541	RDR1/2PM102J
	Other resistors	RDR1/4PM□□□J

OTHERS

Mark	Symbol & Description	Part No.
	JA501 2P Pin jack (LINE OUT)	PKB1011

◎ Power Supply Board Assembly (PWZ1548)

SEMICONDUCTORS

Mark	Symbol & Description	Part No.
△	IC620,IC621	ICP-N10
	IC615	NJM5532DD
△	IC613	NJM7805FA
△	IC614	NJM7912FA
	Q625	2SA933S
	Q621,Q623	2SB715
△	Q617,Q622	2SB857
	Q626	2SC1740S
△	Q619,Q624	2SD1133
	Q618,Q620	2SD755
	D628 - D631	HZ5CLL
△	D620 - D627	10DF2

CAPACITORS

Mark	Symbol & Description	Part No.
	C604,C605 (220 μ F/35V)	PCH1073
	C606,C607,C612,C613 (1000 μ F/35V)	PCH1079
	C602,C603,C620,C621 (47 μ F/50V)	PCH1082
	C624,C625	CFTXA103J50
	C608 - C611,C614 - C619	CKCYF103Z50

RESISTORS

Mark	Symbol & Description	Part No.
	R647 - R650	RN1/4P□□□□F
	Other resistors	RDR1/4PM□□□□J

Primary Board Assembly

SWITCH

Mark	Symbol & Description	Part No.
△	S301 Power switch (POWER)	PSA-009

COIL

Mark	Symbol & Description	Part No.
△	L301 Line filter	PTL1002

CAPACITORS

Mark	Symbol & Description	Part No.
△	C301 - C303 (0.01 μ F/AC125V)	VCG-008

7. ADJUSTMENTS

The adjustments for this unit are given below. Adjustments must be made in the order listed.

● Adjustments and check items

1. Tracking error offset (VR7), focus error offset (VR6) and RF offset (VR2) adjustment
2. RF level (VR1) adjustment
3. LD (Laser Diode) power check
4. Focus servo lock and spindle servo lock check
5. Grating adjustment
6. Tracking error balance adjustment (VR5)
7. Tangential adjustment
8. Radial adjustment
9. Focus gain adjustment (VR3)
10. Tracking gain adjustment (VR4)
11. VCO free-run frequency adjustment (VR8)
12. Method for confirming S character (focus error)
13. MSB adjustment (VR506, VR507)

● Measuring equipment

1. Dual trace oscilloscope
2. Optical power meter
3. Test disc (YEDS-7), 8 cm disc
4. Loop gain adjustment filter
5. Signal generator
6. Frequency counter
7. Other regular measuring equipment

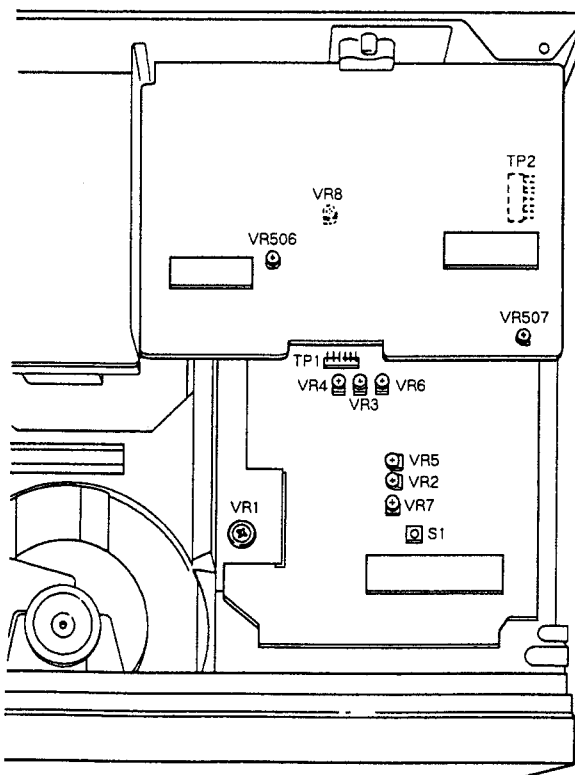
● About the test mode

How to activate and release the test mode

- ① To activate the test mode, turn ON the power switch (S301) with the test mode switch (S1) in the ON position.
- ② The test mode is released by turning the power switch OFF.

The functions of the keys in the test mode are outlined in Table 7-1.

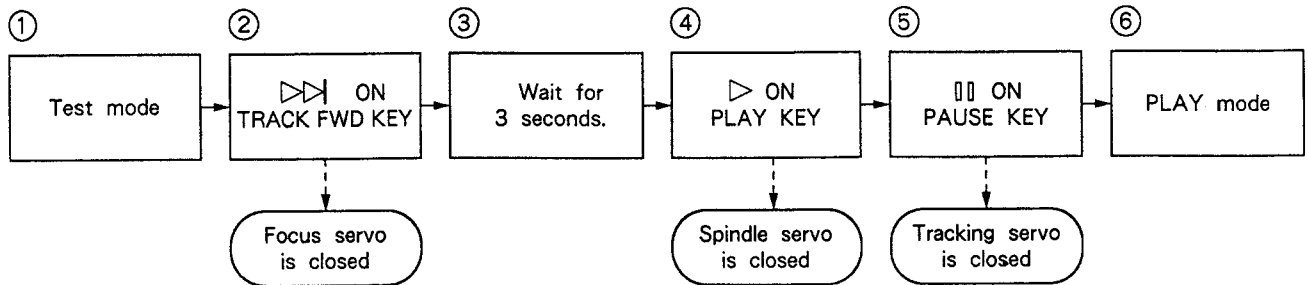
Adjustment Point



In the test mode, focus, tracking and spindle servos must be closed and opened individually. Consequently, the servos must each be closed in the proper sequence (serial sequence) in order to put the machine into the normal play mode. Note also that the machine will not enter the play mode when the PAUSE (||) key is pressed.

For example, in order to change from the stop to the play mode, the function keys must be pressed in the following order.

* In the test mode, the servos must be operated in serial sequence.



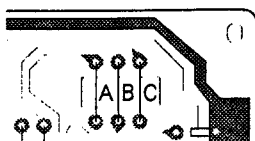
● Key Functions in Test Mode

Symbol	Key name	Function in test mode	Description
▷▷	TRACK FWD	Focus servo close	Turns ON the laser diode, and raises and lowers the focusing actuator to close the focus servo.
▷	PLAY	Spindle servo close	Closes the servo in the CLV-A mode after starting the rotation of the SPDL motor.
	PAUSE	Tracking servo close/open	Acts as a toggle : closes the tracking servo and activates play mode when pressed (provided the focus and spindle servos are closed), at which time the PAUSE indicator illuminates ; opens the tracking servo when pressed again.
□	STOP	Stop	Stops all servos and returns system to its initial state.
△	OPEN/CLOSE	Disc tray open/close	Opens and closes the disc tray. However, pickup does not return to rest on OPEN, and it remains stationary on CLOSE.

Table 7-1

● When performing MANUAL SEARCH

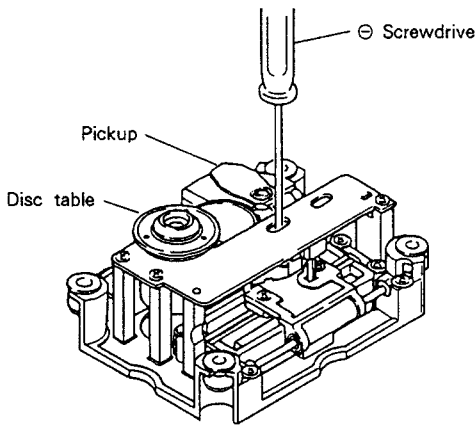
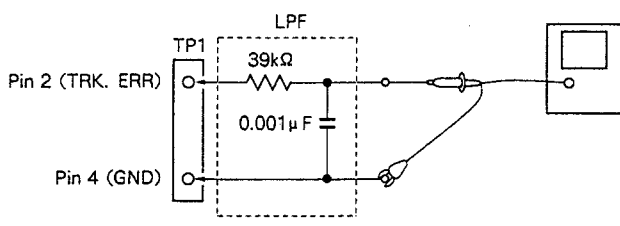
* The MANUAL SEARCH Key function is simulated by connecting jumpers (JP) A, B and C on the FUNCTION BOARD assembly.

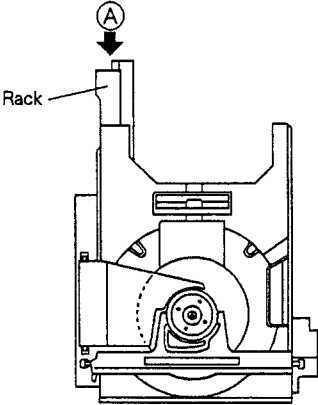
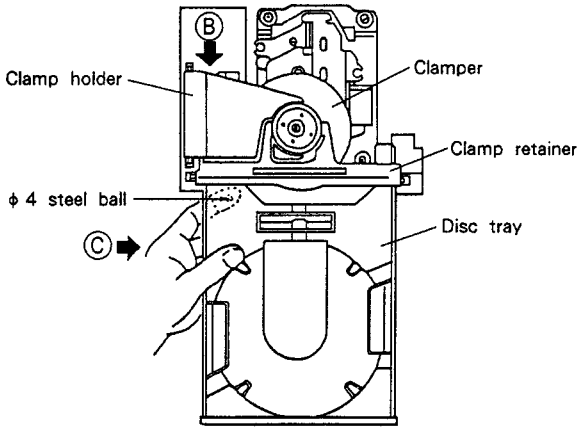
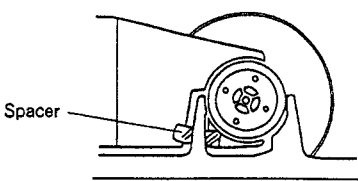
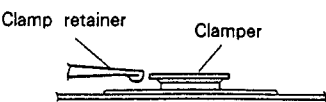


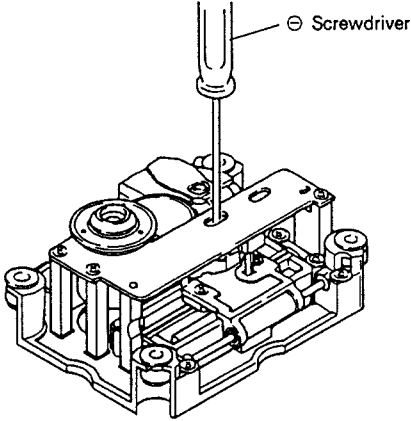
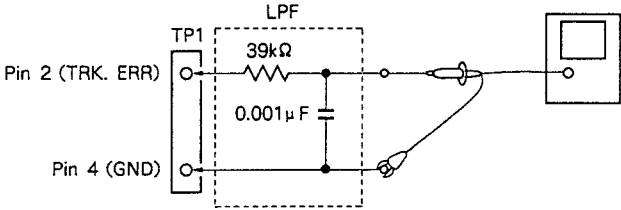
- FUNCTION BOARD assembly, viewed from the pattern side.
- Connecting the jumpers C and B = MANUAL SEARCH REV.
- Connecting the jumpers A and B = MANUAL SEARCH FWD.

	Function	Description
MANUAL SEARCH REV	Carriage reverse (moves inward)	Moves carriage quickly (1cm/s) toward innermost track. Be careful not to move too far as there is no safety device to stop the carriage.
MANUAL SEARCH FWD	Carriage forward (moves outward)	Moves carriage quickly (1cm/s) toward outermost track. Be careful not to move too far as there is no safety device to stop the carriage.

Step No.	Oscilloscope Setting		Test Points	Adjusting Points	Check items/ Adjustment specifications	Adjustment procedure
	V	H				
1 Tracking error offset, focus error offset and RF offset adjustment						
			TP1 Pin 2 (TRK. ERR) TP1 Pin 6 (FCS. ERR) TP1 Pin 1 (RF OUTPUT)	VR5 (TRK. BAL) VR7 (TRK. OFS) VR6 (FCS. OFS) VR2 (RF. OFS)	Tracking error offset 45° 0V ± 50mV FOCUS error offset 0V ± 50mV RF offset 100mV ± 50mV	<ul style="list-style-type: none"> ● Put unit in the TEST mode (see page 30). ● Set VR5 TRK. BAL (tracking balance) to the position about 45° to the left of center. ● Adjust VR7 TRK. OFS (tracking offset) so that the TRK. ERR (tracking error) voltage at TP1 pin 2 becomes 0V ± 50mV. ● Adjust VR6 FCS. OFS (focus offset) so that the FCS. ERR (focus error) voltage at TP1 pin 6 becomes 0V ± 50mV. ● Adjust VR2 RF. OFS (RF offset) so that the RF output voltage at TP1 pin 1 becomes 100mV ± 50mV. <p>Note : When adjusting the tracking offset, always perform "6. Tracking error Balance Adjustment."</p>
2 RF level adjustment						
			TP1 Pin 1 (RF OUTPUT)	VR1 (Laser power)	1.5Vp-p $\pm_{-0}^{+0.2}$ V	<ul style="list-style-type: none"> ● Put unit in the test mode (see page 30). ● Load the test disc and connect the oscilloscope to TP1 pin 1 (RF output), play the test disc, and measure the P-P voltage of the RF waveform. ● Adjust VR1 (Laser power) so that the voltage is 1.5Vp-p $\pm_{-0}^{+0.2}$ V.
3 LD (laser diode) power check						
				Check	Less than 0.13mW	<ul style="list-style-type: none"> ● Put unit in the test mode (see page 30). ● Press the TRACK FWD (▷▷) key to turn ON the laser diode (LD). ● Place the sensor of the optical power meter directly above the objective lens and confirm that the LD power is less than 0.13mW.
4 Focus servo lock and spindle servo lock check						
	0.5V/div	100msec /div	TP1 Pin 1 (RF output)		RF signal is output. Forward (clockwise) rotation	<ul style="list-style-type: none"> ● Set the test disc. ● Put unit in the test mode (see page 30). ● Connect the MANUAL SEARCH FWD JP to move the pickup to the center of the disc. ● Observe the output of TP1 pin 1 (RF output) on the oscilloscope. Confirm that the RF signal is output after the TRACK FWD (▷▷) key is pressed. ● Press the PLAY (▷) key and confirm that the disc rotates at constant speed (approx. 300 rpm) near center of disc in the forward (clockwise) direction ; disc rotate at an abnormal speed or rotate counterclockwise.

Step No.	Oscilloscope Setting		Test Points	Adjusting Points	Check items/ Adjustment specifications	Adjustment procedure
	V	H				
5	Grating Adjustment (1) (When an 8 cm disc is used.)					
						<p>Note : This adjustment can be made by using an 8 cm disc, having pits within the diameter range of 75 mm.</p> <ul style="list-style-type: none"> ● Put unit in the test mode (see page 30). ● Connect the MANUAL SEARCH FWD JP to move the pickup to the center of the disc, so that the grating adjustment screw of the pickup can be viewed through the oval hole (one of the oval holes which is near to the spindle motor) on the base plate of the servo mechanism. ● As shown in Fig. 7-1, insert a (slotted) ⊖ screwdriver from the top of the mechanism and check that the grating adjusting screw can be rotated. ● Mount the test disc. ● Press the TRACK FWD key (▷▷) and PLAY key (▷) in sequence to close the focus servo and spindle servo (do not close the tracking servo). ● Observe the TRK.ERR (tracking error) waveform at TP1 pin 2 on an oscilloscope, inserting a 4 kHz low-pass filter (see Fig. 7-2).
	0.5V/div	5msec/div	TP1 Pin 2 (TRK. ERR)	Grating adjustment screw Grating adjustment screw	Null point Maximum amplitude	<ul style="list-style-type: none"> ● Insert a ⊖ screwdriver into the grating hole, turn and find the null point (see Photo 7-1). ● Next, slowly turn the ⊖ screwdriver COUNTERCLOCKWISE from the null point and adjust until the waveform (tracking error signal) reaches maximum amplitude (see Photo 7-2). <p>Note : Use caution since inserting the ⊖ screwdriver forcefully will cause the pickup unit to tilt upward.</p> <ul style="list-style-type: none"> ● Lastly, make sure that there is no major fluctuation in the p-p voltage of the tracking error signal (do not insert the cutoff 4 kHz low-pass filter) when the pickup is moved to the inner and outer periphery. If there is a difference of more than ±10% again turn the grating adjustment screw and adjust the tracking error signal to maximum.
						 <p>Fig. 7-1</p>
						 <p>Fig. 7-2</p>

Step No.	Oscilloscope Setting		Test Points	Adjusting Points	Check items/ Adjustment specifications	Adjustment procedure
	V	H				
5'	Grating adjustment (2) (When 8 cm disc is not used.)					
 <p>Fig. 7-3</p>			<p>The following procedure tells how to adjust the grating without using 8 cm disc. Remove the disc tray to perform this adjustment.</p> <p>● Removal of the disc tray</p> <ol style="list-style-type: none"> 1. Press the rear edge of the rack, (*1) marked A in Fig. 7-3, while pulling the disc tray out to the position where it catches, illustrated in Fig. 7-4. (*1) When the rear edge of rack A is pressed, first the disc clamp is released. If you continue pressing after it has been released completely, the disc tray is ejected. 2. While pulling the clamp holder B (see Fig. 7-4) upward with the right hand, hold the tray as indicated by C in the left hand and pull it outward. Take care not to allow the $\phi 4$ steel ball to fall (we recommend holding the ball in place with the left index finger while extracting the tray.) 			
 <p>Fig. 7-4</p>						
 <p>Fig. 7-5</p>						
 <p>Fig. 7-6</p>						

Step No.	Oscilloscope Setting		Test Points	Adjusting Points	Check items/ Adjustment specifications	Adjustment procedure
	V	H				
						 <p>Fig. 7-7</p>  <p>Fig. 7-8</p> <ul style="list-style-type: none"> ● Put unit in the test mode (see page 30). ● Connect the MANUAL SEARCH FWD JP to move the pickup to the center of the disc, so that the grating adjustment screw of the pickup can be viewed through the oval hole (one of the oval holes which is near to the spindle motor) on the base plate of the servo mechanism. ● As shown in Fig. 7-7, insert a (slotted) ⊖ screwdriver from the top of the mechanism and check that the grating adjusting screw can be rotated. ● Mount the test disc; be sure to insert a 3-5 mm spacer (if no spacer is available, use a hex wrench) between the clamp holder and clamp retainer, as shown in Fig. 7-5. ● Confirm that the clammer and the clamp retainer are not contacting one another (Fig. 7-6). ● Press the TRACK FWD (▷▷) and the PLAY (▷) keys sequentially to close the focus and spindle servos (do not close the tracking servo). ● Insert a 4 kHz-cutoff low pass filter: between the oscilloscope and TP1 pins 2 (TRK. ERR) and 4 (GND) as shown in Fig. 7-8 and observe the waveform of TP1 pin 2 (tracking error) on the oscilloscope.
	0.5V/div	5msec/div	TP1 Pin 2 (TRK. ERR)	Grating adjusting screw Grating adjusting screw	Null point Maximum amplitude	<ul style="list-style-type: none"> ● Turn the grating adjusting screw with the ⊖ screwdriver to find the null point (see Photo 7-1). ● Next, slowly turn the ⊖ screwdriver COUNTERCLOCKWISE and adjust to the point where the waveform (tracking error signal) first achieves its maximum amplitude (see Photo 7-2). <p>Note: Avoid applying pressure to the ⊖ screwdriver while adjusting the screw. Doing so causes the pickup to move inward, making adjustment more difficult.</p> <ul style="list-style-type: none"> ● Lastly, remove the low pass filter and confirm that the tracking error signal (do not insert the cutoff 4 kHz low-pass filter) p-voltage does not greatly vary when the pickup is moved to the innermost and outermost tracks of the disc. <p>If the levels diverge by ±10% or more, re-adjust the maximum error amplitude point by turning the grating adjustment screw.</p>

Step No.	Oscilloscope Setting		Test Points	Adjusting Points	Check items/ Adjustment specifications	Adjustment procedure
	V	H				
						<p>Re-mount the disc tray according to the following procedure when the grating adjustment is complete.</p> <ol style="list-style-type: none"> 1. Remove the disc and the spacer. 2. While lifting the clamp holder [marked ① in Fig. 7-4] with the right hand, hold the tray in the left hand as indicated by ② and slide the slide base into the hard resin fittings on the loading base as shown in Fig. 7-9 to re-insert the disc tray. At this time, be sure to hold the steel ball in place with the index finger of the left hand. Also, be careful that the front panel is not damaged by the slide base and steel ball's bearing (in the slide base) coming into contact with the panel. 3. Insert the slide base so that it fits into the two hard resin fittings at the rear of the loading base (see Fig. 7-10). 4. Insert the tray tightly.

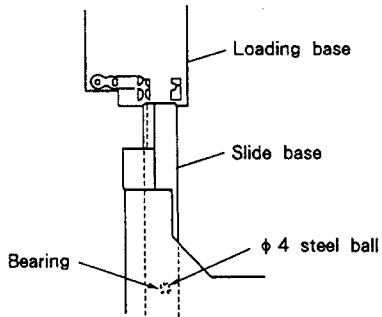


Fig. 7-9

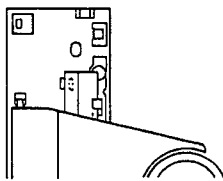


Fig. 7-10

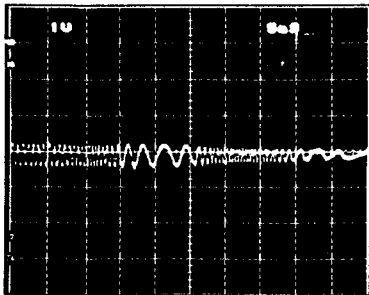


Photo 7-1
Null point

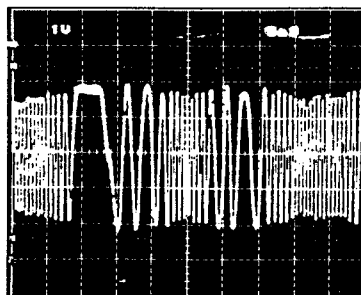


Photo 7-2
Maximum amplitude

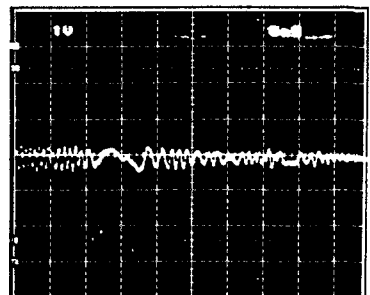
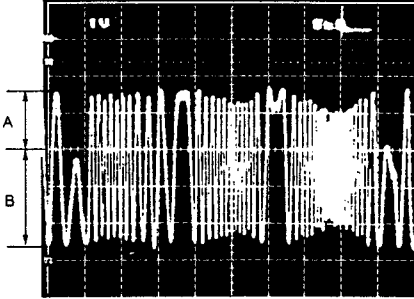

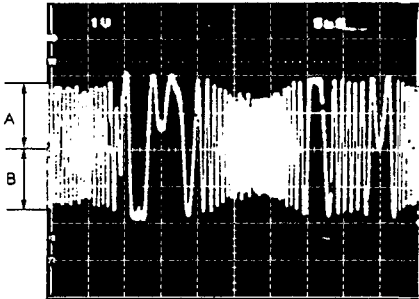
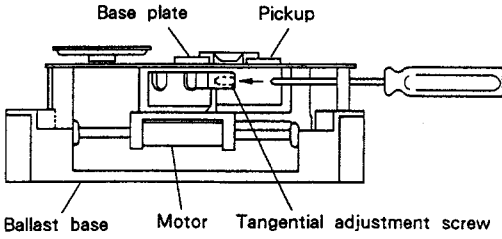
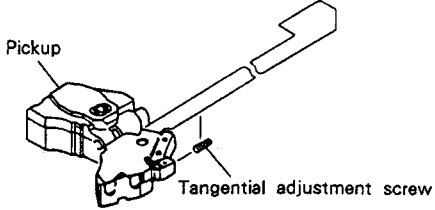


Photo 7-3
This is not the null-point waveform.

Step No.	Oscilloscope Setting		Test Points	Adjusting Points	Check items/ Adjustment specifications	Adjustment procedure	
	V	H					
6 Tracking error balance adjustment							
	0.5V/div	5msec/div	TP1 Pin 2 (TRK. ERR)	VR5 (TRK. BAL)		<ul style="list-style-type: none"> ● Load the test disc. ● Put unit in the test mode (see page 30). ● Connect the MANUAL SEARCH FWD JP to move the pickup to the center of the disc. ● Press the TRACK FWD (▷▷) and PLAY (▷) keys sequentially to cause the disc to rotate. ● Observe TP1 pin 2 TRK. ERR (tracking error) on the oscilloscope and adjust VR5 TRK. BAL (tracking balance) to eliminate the DC elements from the tracking error signal. 	
							
			<p>A ≠ B</p> <p>Photo 7-4 DC elements mixed in signal</p>				
							
			<p>A = B</p> <p>Photo 7-5 DC elements eliminated</p>				
7 Tangential adjustment (Perform the adjustment after removing the mechanism block, or after removing the AUDIO BOARD Assembly at the rear.)							
						<ul style="list-style-type: none"> ● Put unit in the test mode (see page 30). ● Open the tray and load the test disc. ● Connect the MANUAL SEARCH FWD JP to move the pickup to the center of the disc. ● Insert a hex wrench into the tangential adjustment screw section from the rear of the mechanism. ● Close the tray. 	
						<p>Note: Do not use an L-shaped hex wrench. Use one such as shown to the left. Using an L-shaped hex wrench can cause the tray to come loose (see page 34 5'. Grating Adjustment (2)).</p> <ul style="list-style-type: none"> ● Press the TRACK FWD (▷▷), PLAY (▷), and PAUSE () keys sequentially to close the all servos (PAUSE indicator will illuminate). 	
	<p>Fig. 7-11</p>						

Step No.	Oscilloscope Setting		Test Points	Adjusting Points	Check items/ Adjustment specifications	Adjustment procedure
	V	H				
		200nsec /div	TP1 Pin 1 RF output	Tangential adjustment screw	Sharpest possible eye pattern	<ul style="list-style-type: none"> ● Observe TP1 pin 1 (RF output) on the oscilloscope and adjust the tangential adjustment screw to achieve the sharpest possible eye pattern. ● When the whole waveform becomes clear, concentrate on sharpening the fine lines forming the diamond at the center of the eye pattern (see Photo 7-8). Adjust until the fine lines on all four sides of the diamond are both sharply defined and dense, as shown in Photo 7-6. <p>Note: Use a hex wrench to raise the pickup some what while making this adjustment.</p>

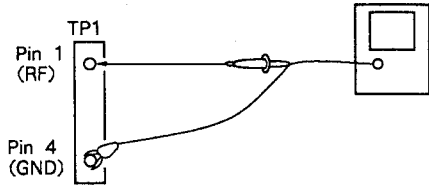
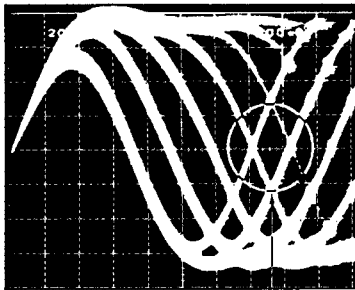


Fig. 7-12



Part to be observed

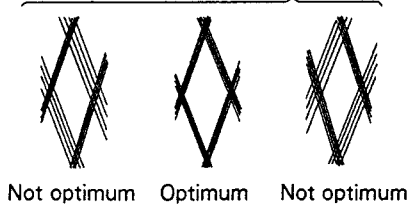


Photo 7-6

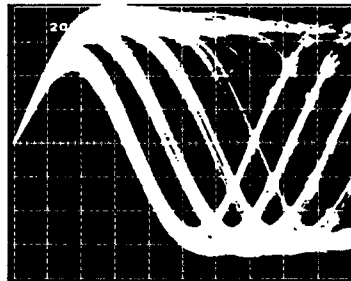


Photo 7-7

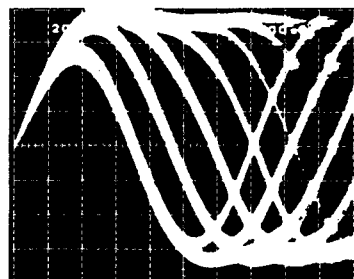


Photo 7-8

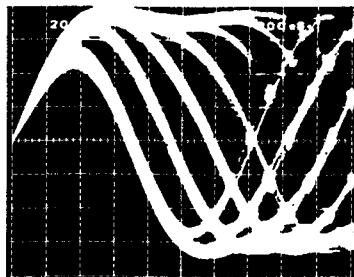


Photo 7-9

Step No.	Oscilloscope Setting		Test Points	Adjusting Points	Check items/ Adjustment specifications	Adjustment procedure
	V	H				
8	Radial adjustment					
			TP1 Pin 1 (RF output)	Radial adjustment screw	Sharpest possible eye pattern	<p>Remove the disc tray before beginning this adjustment.</p> <p>Note : Refer to page 34 "5. Grating adjustment (2)" for the removal of the disc tray.</p> <ul style="list-style-type: none"> ● Load the test disc. ● Put unit in the test mode (see page 30). ● Connect the MANUAL SEARCH FWD JP to move the pickup to the center of the disc, so that tangential adjustment screw can be viewed from the top (refer to Fig. 7-11). ● Press the TRACK FWD (▷▷), PLAY (▷), and PAUSE (⏸) keys sequentially to close all servos (PAUSE indicator will illuminate). ● Observe TP1 pin 1 (RF output) on the oscilloscope and adjust the radial adjustment screw to achieve the sharpest possible eye pattern. (Fig. 7-13) ● When the whole waveform becomes clear, concentrate on sharpening the fine lines forming the diamond at the center of the eye pattern (see Photo 7-8). Adjust until the fine lines on all four sides of the diamond are both sharply defined and dense, as shown in Photo 7-6. ● Perform the tangential adjustment and the radial adjustment twice or more alternately. ● When the adjustment is completed, replace the disc tray (see page 36).

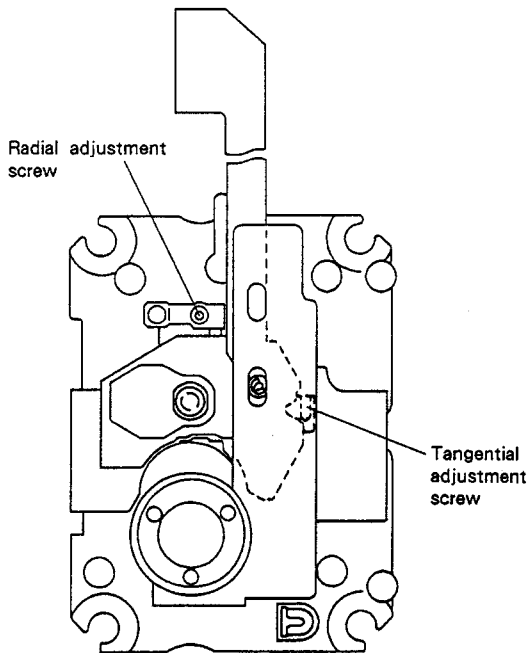


Fig. 7-13

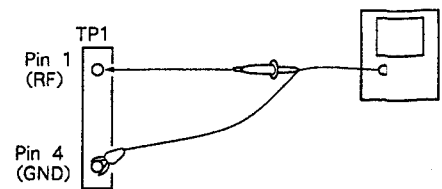


Fig. 7-14

Step No.	Oscilloscope Setting		Test Points	Adjusting Points	Check items/ Adjustment specifications	Adjustment procedure
	V	H				
9 Focus gain adjustment						
	20mV/div CH1 (X) 5mV/div CH2 (Y) (prove 10 : 1)		X-axis : TP1 Pin 5 (FCS. IN) Y-axis : TP1 Pin 6 (FCS. ERR)	VR3 (FCS. GAN)	Phase difference of 90°	<ul style="list-style-type: none"> ● In the POWER OFF state, connect the oscilloscope and oscillator as shown in Fig. 7-15. ● Set the unit to the normal PLAY mode. ● Turn ON the power to the oscillator and set it to output a 1.2kHz 1Vp-p signal. <p>Note : Some oscillators discharge a DC voltage when turned on . It is therefore recommended that the oscillator be connected after it has been turned on.</p> <ul style="list-style-type: none"> ● Adjust VR3 FCS.GAN (focus gain) so that the Lissajous's figure becomes a horizontal circle (phase difference of 90°)

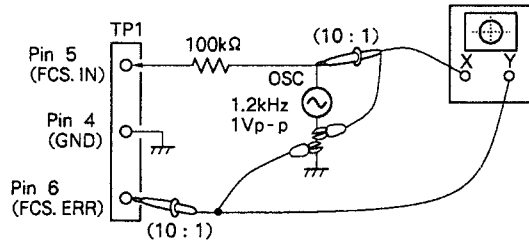


Fig. 7-15

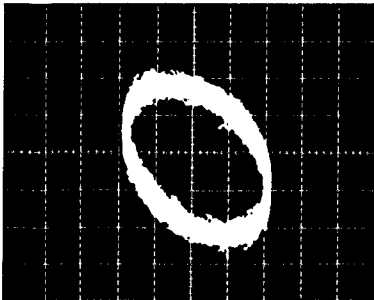


Photo 7-10
High gain

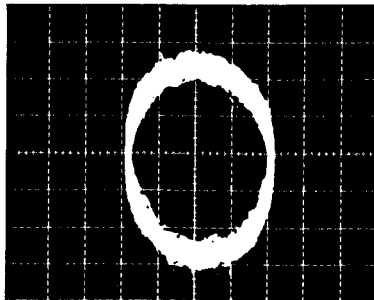


Photo 7-11
Optimum gain

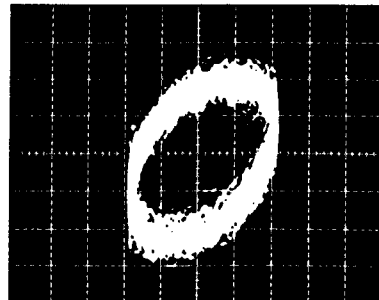


Photo 7-12
Low gain

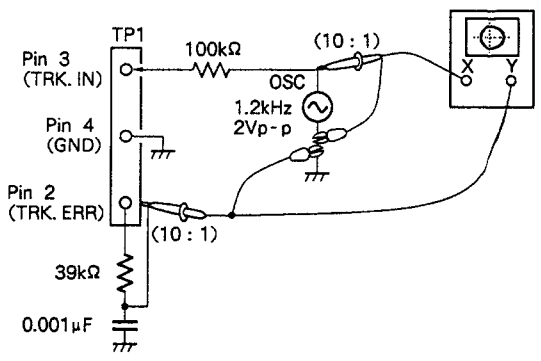
Step No.	Oscilloscope Setting		Test Points	Adjusting Points	Check items/ Adjustment specifications	Adjustment procedure
	V	H				
10	Tracking gain adjustment					
	50mV/div CH1 (X) 5mV/div CH2 (Y) (probe 10 : 1)	X-axis : TP1 Pin 3 (TRK. IN) Y-axis : TP1 Pin 2 (TRK. ERR)	VR4 (TRK. GAN)	Phase difference of 90°	<ul style="list-style-type: none"> ● In the POWER OFF state, connect the oscilloscope and oscillator as shown in Fig. 7-16. ● Set the unit to the normal PLAY mode. ● Turn ON the power to the oscillator and set it to output a 1.2kHz 2Vp-p signal. <p>Note : some oscillators discharge a DC voltage when turned on . It is therefore recommended that the oscillator be connected after it has been turned on.</p> <ul style="list-style-type: none"> ● Adjust VR4 TRK.GAN (tracking gain) so that the Lissajous's figure becomes a horizontal circle (phase difference of 90°). 	

Fig. 7-16

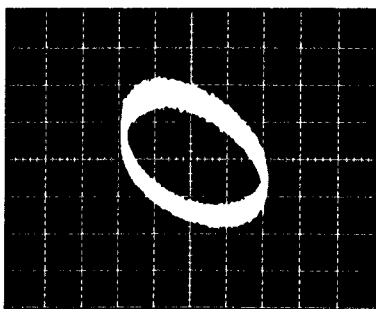


Photo 7-13
High gain

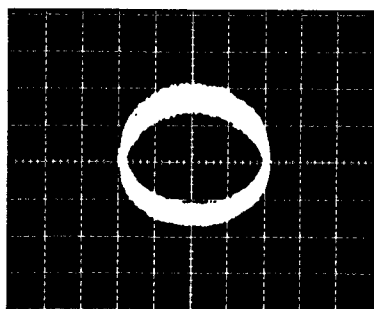


Photo 7-14
Optimum gain

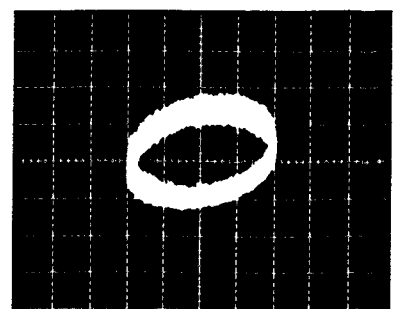


Photo 7-15
Low gain

Step No.	Oscilloscope Setting		Test Points	Adjusting Points	Check items/ Adjustment specifications	Adjustment procedure
	V	H				
11 VCO free-run frequency adjustment						
			TP2 Pin 2 (PLCK)	VR8 (VCO. ADJ)	4.275 ± 0.025MHz	<ul style="list-style-type: none"> ● Put unit in the test mode (see page 30). ● Short the ASY and GND jumper with a ⊖ screwdriver or similar tool (see Fig. 7-17). ● Connect a frequency counter capable of measuring frequencies of 10MHz and above to TP2 pin 2 (PLCK). ● Adjust VR8 (VCO adjustment) so that the frequency counter reading becomes 4.275 ± 0.025MHz.
12 Method for confirming S character (focus error)						
			TP1 Pin 6 (FCS. ERR)			<ul style="list-style-type: none"> ● Put unit in the test mode (see page 30). ● Ground TP1 pin 5 FCS.IN (focus in) to GND. ● Observe the waveform output by TP1 pin 6 FCS.ERR (focus error) when the TRACK FWD (>D) key is pressed.

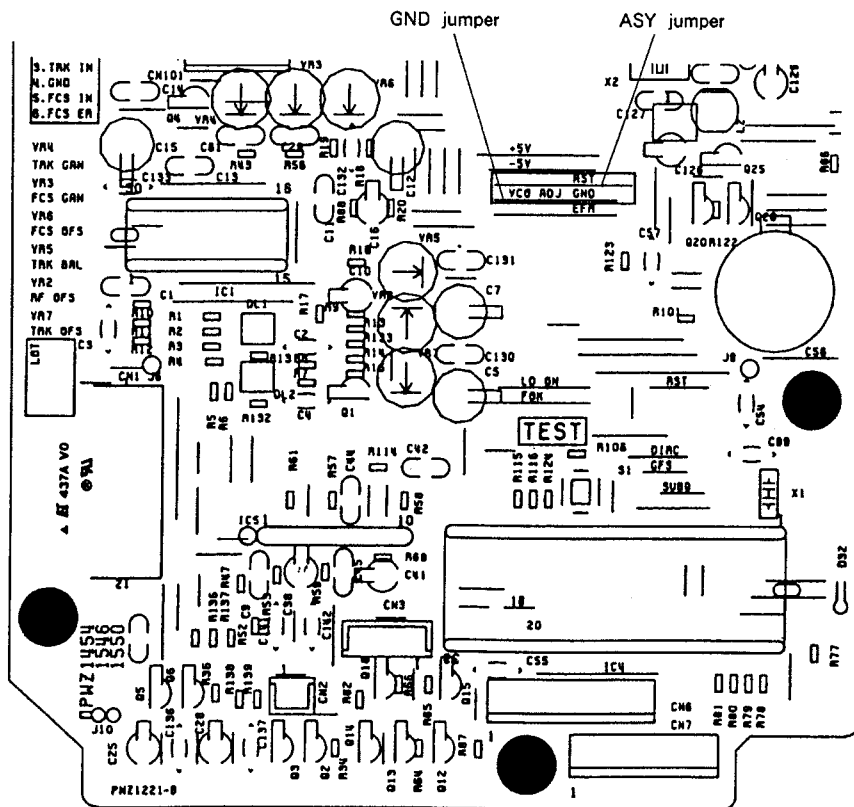
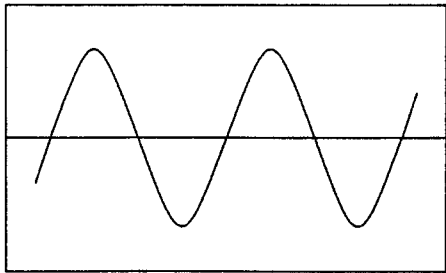


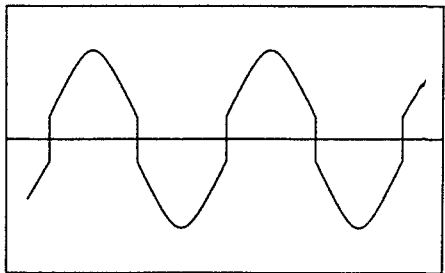
Fig. 7-17 ASY and GND Jumper position

Step No.	Oscilloscope Setting		Test Points	Adjusting Points	Check items/ Adjustment specifications	Adjustment procedure
	V	H				
13 MSB adjustment						
	5mV/div	0.2msec /div	JA1 LINE OUTPUT terminal (L CH)	VR506	Sine wave	<ul style="list-style-type: none"> ● Set the unit to the normal PLAY mode. ● Playback the track 20 (-60 dB, 1kHz, Lch, Rch) of the test disc (YEDS-7). Connect the oscilloscope to the Lch of the LINE OUTPUT terminal (JA1), and observe the audio output waveform. ● Adjust VR506 MSB (L ch) so that the sine wave is obtained on the oscilloscope. ● Adjust VR507 (R ch) in the same way.
			JA1 LINE OUTPUT terminal (R CH)	VR507	Sine wave	

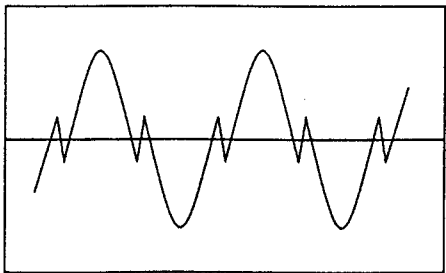
● ZERO cross distortion waveform



OK



NG



NG

7. RÉGLAGE

On trouvera ci-après les réglages requis pour cet appareil. Ils doivent être exécutés dans l'ordre donné.

● Réglages et items de vérification

1. Réglage de décalage d'erreur d'alignement (VR7), de mise au point (VR6) et de décalage RF (VR2).
2. Réglage du niveau RF (VR1)
3. Vérification d'alimentation de diode laser (LD).
4. Vérification de verrouillage le servo de mise au point et de verrouillage le servo d'axe
5. Réglage du grincement
6. Réglage d'équilibre d'erreur d'alignement (VR5)
7. Réglage tangentiel
8. Réglage radial
9. Réglage de gain de mise au point (VR3)
10. Réglage de gain d'alignement (VR4)
11. Réglage de fréquence libre VCO (VR8)
12. Méthode de confirmation du caractère S (erreur de mise au point)
13. Réglage de MSB (VR506, VR507)

● Matériel de mesure

1. Oscilloscope cathodique à deux faisceaux.
2. Wattmètre optique
3. Disque d'essai (YEDS-7), disque de 8 cm
4. Filtre d'ajustement de gain de boucle
5. Générateur de signal
6. Fréquencemètre
7. Tournevis, pinces, fer à souder, etc.

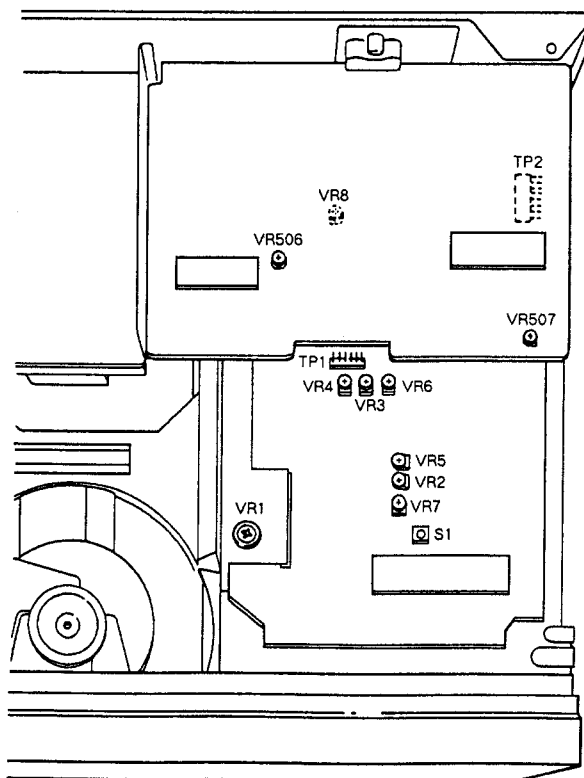
● Apropos du mode d'essai

Mise en/hors service du mode d'essai

- ① Pour actualiser le mode d'essai, allumer (ON) l'interrupteur d'alimentation (S301) après avoir placé l'interrupteur du mode d'essai (S1) à la position ON.
- ② Le mode d'essai est annulé en ramenant l'interrupteur d'alimentation sur OFF.

Les fonctions des touches en mode d'essai sont décrites au Tableau 7-1.

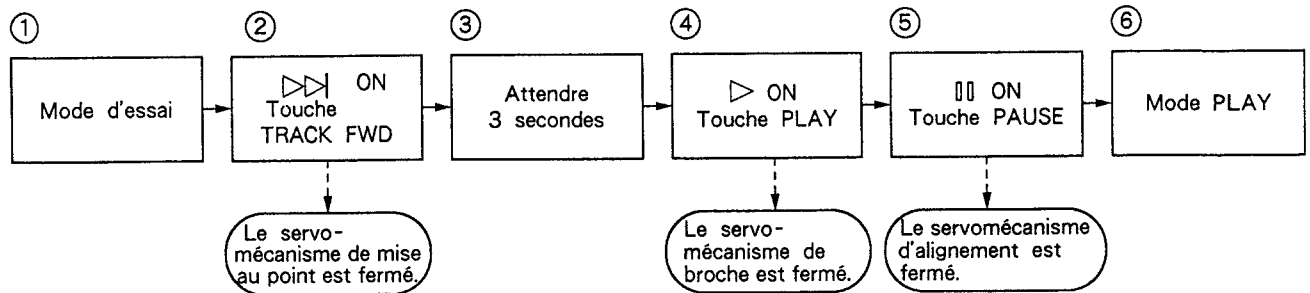
Points de réglage



En mode d'essai, mise au point, alignement et d'axe servos doivent être fermés et ouverts individuellement. En conséquence, les servos doivent chacun être fermés dans la séquence correcte (séquence sérielle) afin de placer l'appareil en mode de lecture normale. Remarquer également que l'appareil ne se placera pas en mode de lecture par une poussée sur la touche PAUSE (⏸).

Par exemple, pour passer du mode d'arrêt au mode de lecture, les touches de fonction doivent être actionnées dans l'ordre suivant.

* En mode d'essai, les servos doivent être opérés en séquence sérielle.



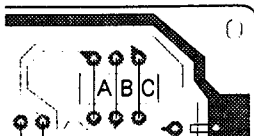
● Fonctions des touches en mode d'essai

Symbole	Nom de touche	Fonction en mode d'essai	Description
▷▷	TRACK FWD	Servo de mise au point fermé	Allume la diode laser et élève ou abaisse l'actuateur de mise au point pour fermer le servo de mise au point.
▷	PLAY	Servo d'axe fermé	Ferme le servo en mode CLV-A après cognement du moteur d'axe.
⏸	PAUSE	Fermeture/ouverture de servo d'alignement	Agit comme interrupteur articulé: ferme le servo d'alignement et active le mode de lecture quand poussé (pourvu que les servos de mise au point et d'alignement soient fermés), auquel moment le témoin PAUSE s'allume; ouvre le servo d'alignement à la poussée suivante.
□	STOP	STOP	Arrête tous les servos et ramène le système à l'état initial.
△	OPEN/CLOSE	Ouverture/fermeture du plateau de disque	Ouvre et ferme le plateau du disque. Cependant, le capteur ne revient pas à la position de repos à OPEN et il reste stationnaire à CLOSE.

Tableau 7-1

● Lors d'une recherche manuelle

* La fonction de touche MANUAL SEARCH est simulée en recordant les câbles de fermeture de circuit (JP) A, B et C sur l'assemblage FUNCTION BOARD.



● Assemblage FUNCTION BOARD du côté avec le schéma.

- Raccordement des câbles de fermeture de circuit C et B = MANUAL SEARCH REV.
- Raccordement des câbles de fermeture de circuit A et B = MANUAL SEARCH FWD.

	Fonction	Description
MANUAL SEARCH REV	Inversion du chariot (déplacement vers l'intérieur)	Déplace rapidement (1 cm/sec) le chariot vers la plage la plus au centre. Prendre garde à ne pas déplacer trop loin car il existe pas de dispositif de sécurité pour arrêter le chariot.
MANUAL SEARCH FWD	Avance du chariot (déplacement vers l'extérieur)	Déplace rapidement (1 cm/sec) le chariot vers la plage la plus à l'extérieur. Prendre garde à ne pas déplacer trop loin car il n'existe pas de dispositif de sécurité pour arrêter le chariot.

N° de étape	Réglage d'oscilloscope		Points d'essai	Points de réglage	Postes de contrôle / Spécifications de réglage	Procédure de réglage
	V	H				
1 Réglage de décalage d'erreur d'alignement, de mise au point et de décalage RF.						
			TP1 Broche 2 (TRK. ERR)	VR5 (TRK. BAL) VR7 (TRK. OFS)	Décalage d'erreur d'alignement 45° 0V ± 50mV	<ul style="list-style-type: none"> ● Placer l'appareil en mode d'essai (voir page 44). ● Régler VR5 TRK. BAL (équilibrage d'alignement) à la position environ à 45° à la gauche du centre. ● Régler VR7 TRK. OFS (décalage d'alignement) de sorte que la tension TRK. ERR (erreur d'alignement) à TP1 broche 2 devienne 0V ± 50mV. ● Régler VR6 FCS. OFS (décalage de mise au point) de sorte que la tension FCS. ERR (erreur de mise au point) à TP1 broche 6 devienne 0V ± 50mV. ● Régler VR2 RF. OFS (décalage RF) de sorte que la tension de sortie RF à TP1 broche 1 devienne 100mV ± 50mV. <p>Remarque : Lors de l'ajustement de la compensation, effectuer toujours "6. Réglage d'équilibre d'erreur d'alignement".</p>
			TP1 Broche 6 (FCS. ERR)	VR6 (FCS. OFS)	Décalage d'erreur de mise au point 0V ± 50mV	
			TP1 Broche 1 (RF OUTPUT)	VR2 (RF. OFS)	Décalage RF 100mV ± 50mV	
2 Réglage du niveau RF						
			TP1 Broche 1 (RF OUTPUT)	VR1 (Puissance laser)	1,5Vc-c \pm $\frac{0,2}{0}$ V	<ul style="list-style-type: none"> ● Placer l'appareil en mode d'essai (voir page 44). ● Installer le disque d'essai et raccorder l'oscilloscope à TP1 broche 1 (sortie RF), reproduire le disque d'essai et mesurer la tension P-P de la forme d'onde RF. ● Régler VR1 (puissance laser) de façon que la tension soit de 1,5Vc-c \pm $\frac{0,2}{0}$ V.
3 Vérification d'alimentation de diode laser (LD)						
				Vérification	Moins de 0,13mW	<ul style="list-style-type: none"> ● Placer l'appareil en mode d'essai (voir page 44). ● Appuyer sur les touches TRACK FWD (▷▷) pour allumer la diode laser (LD). ● Placer le puissance-mètre optique directement sur la lentille et vérifier que la puissance de la diode laser (LD) est inférieure à 0,13mW.
4 Vérification de verrouillage le servo de mise au point et de verrouillage le servo d'axe						
	0,5V/div	100msec /div	TP1 Broche 1 (sortie RF)		Le signal RF est fourni. Rotation avant (Sens des aiguilles)	<ul style="list-style-type: none"> ● Installer le disque d'essai. ● Placer l'appareil en mode d'essai (voir page 44). ● Reccorder le câble MANUAL SEARCH FWD JP pour amener le capteur au centre du disque. ● Observer la sortie de TP1 broche 1 (sortie RF) sur l'oscilloscope. Confirmer que le signal haute fréquence est fourni après que la touche TRACK FWD (▷▷) est actionnée. ● Appuyer sur la touche PLAY (▷) et confirmer que le disque tourne à vitesse constante (env. 300 tr/mn près du centre du disque) dans le sens avant (sens des aiguilles). Il peut arriver que le disque ne tourne pas ou tourne dans le sens contraire des aiguilles.

N° de étape	Réglage d'oscilloscope		Points d'essai	Points de réglage	Postes de contrôle / Spécifications de réglage	Procédure de réglage
	V	H				
5 Réglage du grincement (1) (Lorsqu'un disque de 8 cm est utilisé)						
						<p>Remarque : Ce réglage peut être effectué en utilisant un disque de 8 cm, dont les cavités se trouvent dans un diamètre de 75 mm.</p> <ul style="list-style-type: none"> ● Régler l'appareil en mode d'essai (voir page 44). ● Raccorder le câble MANUAL SEARCH FWD JP pour amener le capteur au centre du disque, de façon que la vis d'ajustement du grincement du capteur puisse être vue à travers le trou ovale (un des trous ovales près du moteur à broche) sur la plaque de base du mécanisme d'asservissement. ● Comme illustré sur la Fig. 7-1, introduire un ⊖ tournevis (moins) par le haut du mécanisme de sorte que la vis de réglage de grincement puisse être tournée. ● Installe le disque d'essai. ● Appuyer sur la touche TRACK FWD (▷▷) et PLAY (▷) en séquence pour allumer le servo de mise au point et le servo d'axe (ne pas fermer le servo d'alignement). ● Observer la forme d'onde TRK.ERR (erreur d'alignement) à TP1 broche 2 sur un oscilloscope, en insérant un filtre passebas de 4 kHz (voir Fig. 7-2).
						<ul style="list-style-type: none"> ● Insérer un ⊖ tournevis dans l'orifice du grincement, le tourner et rechercher le point nul (voir Photo 7-1). ● Tourner ensuite lentement le ⊖ tournevis DANS LE SENS CONTRAIRE DES AIGUILLES à partir du point nul jusqu'à ce que la forme d'onde (signal d'erreur d'alignement) atteigne l'amplitude maximale (voir Photo 7-2). <p>Remarque : Agir avec précaution car une insertion forcée du ⊖ tournevis provoquera un flottement du capteur vers l'intérieur.</p> <ul style="list-style-type: none"> ● Finalement, confirmer qu'il n'y a pas de fluctuation importante dans la tension c-c du signal d'erreur d'alignement (ne pas insérer le filtre passe-bas 4 kHz) quand le capteur est déplacé vers la périphérie intérieure et vers la périphérie extérieure. Si l'on constate une différence supérieure à 10% tourner à nouveau la grincement et régler le signal d'erreur d'alignement au maximum.

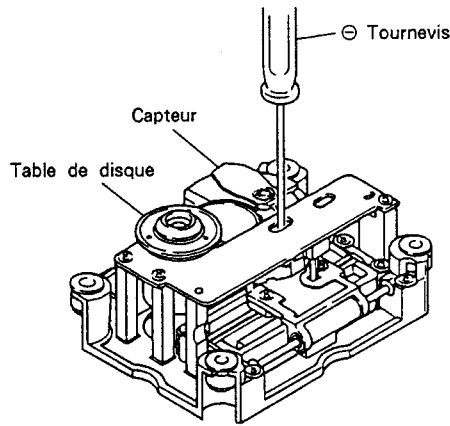


Fig. 7-1

0,5V/div	5msec/div	TP1 Broche 2 (TRK. ERR)	Vis d'ajustement de grincement	Point nul
			Vis d'ajustement de grincement	Amplitude maximale

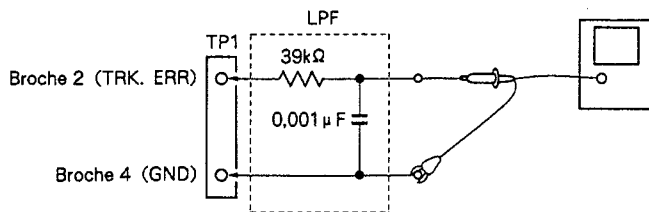
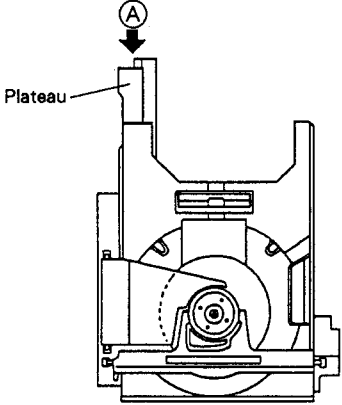
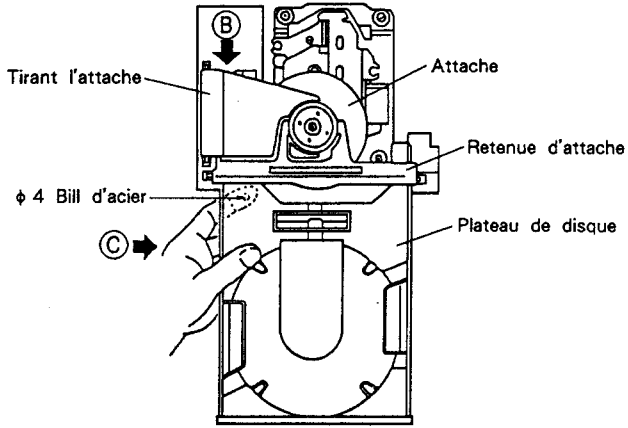
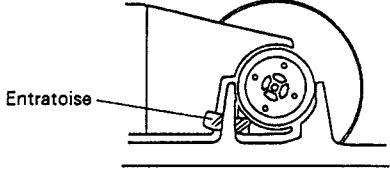
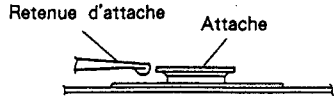
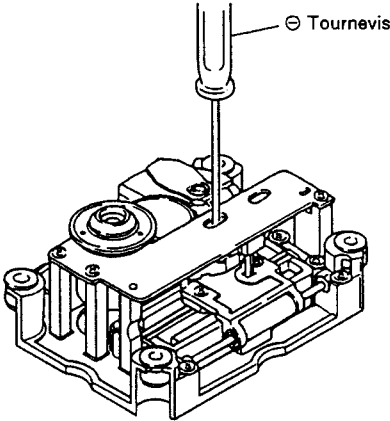
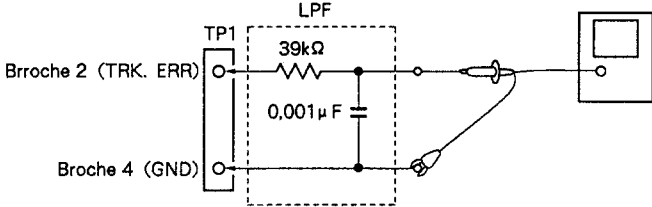


Fig. 7-2

N° de étape	Réglage d'oscilloscope		Points d'essai	Points de réglage	Postes de contrôle / Spécifications de réglage	Procédure de réglage
	V	H				
5'	Réglage du grincement (2) (Lorsqu'un disque de 8 cm n'est utilisé)					
 <p>Plateau</p>			<p>Ce réglage est effectué si aucun disque de 8 cm n'est disponible et que le réglage du grincement (1) ne peut être effectué. Retirer le plateau du disque pour procéder à ce réglage.</p> <ul style="list-style-type: none"> ● Retrait du plateau du disque 			
 <p>Tirant l'attache</p> <p>Attache</p> <p>Retenue d'attache</p> <p>φ 4 Bill d'acier</p> <p>Plateau de disque</p>			<ol style="list-style-type: none"> 1. Pousser sur le bord arrière à l'endroit marqué A sur la Fig. 7-3, (* 1) tout en retirant le plateau du disque vers la position où il tient, comme illustré sur la Fig. 7-4. (*1) Lorsqu'on appuie à l'arrière de la crémaillère A, le dispositif de maintien du disque est déverrouillé. Une pression prolongée au-delà de l'ouverture complète éjecte le tiroir du disque. 2. Tout en tirant l'attache B (voir Fig. 7-4) vers le haut de la main droite, tenir le plateau comme indiqué par C de la main gauche et tirer vers l'extérieur. Prendre garde à ne pas laisser tomber les bills d'acier. Il est conseillé de maintenir la bille en place par l'index gauche tout en extrayant le plateau. 			
 <p>Entratoise</p>						
 <p>Retenue d'attache</p> <p>Attache</p>						

N° de étape	Réglage d'oscilloscope		Points d'essai	Points de réglage	Postes de contrôle / Spécifications de réglage	Procédure de réglage
	V	H				
						<ul style="list-style-type: none"> ● Placer l'appareil en mode d'essai (voir page 44). ● Raccorder le câble MANUAL SEARCH FWD JP pour amener le capteur au centre du disque, de façon que la vis d'ajustement du grincement du capteur puisse être vue à travers le trou ovale (un des trous ovales près du moteur à broche) sur la plaque de base du mécanisme d'asservissement. ● Comme-illustré sur la Fig. 7-7, introduire un ⊖ tournevis (moins) par le haut du mécanisme de sorte que la vis de réglage de grincement puisse être tournée. ● Installer le disque d'essai ; veiller à insérer une entretoise de 3 - 5mm (si aucune entretoise n'est disponible, se servir d'une clé hexagonale) entre l'attache et la retenue d'attache illustré sur la Fig. 7-5. ● Confirmer que l'attache et la retenue ne fasse pas contact l'une sur l'autre (Fig. 7-6). ● Appuyer sur les touches TRACK FWD (▷) et PLAY (▷) en séquence pour fermer les servos de mise au point et d'axe (ne pas fermer le servo d'alignement). ● Installer un filtre passe-bas de coupure à 4kHz entre l'oscilloscope et TP1 broche 2 (TRK. ERR) et 4 (GND) comme illustré sur la Fig. 7-8 et observer la forme d'onde de TP1 broche 3 (erreur d'alignement) sur l'oscilloscope.
						 <p style="text-align: center;">Fig. 7-7</p>  <p style="text-align: center;">Fig. 7-8</p>
	0,5V/div	5msec /div	TP1 Broche 2 (TRK. ERR)	Vis d'ajustement de grincement Vis d'ajustement de grincement	Point nul Amplitude maximale	<ul style="list-style-type: none"> ● Tourner la vis d'ajustement de grincement à l'aide du ⊖ tournevis pour trouver le point nul (voir Photo 7-1). ● Tourner ensuite lentement la ⊖ tournevis DANS LE SENS CONTRAIRE DES AIGUILLES du point nul et régler au point où la forme d'onde (signal d'erreur d'alignement) arrive à son amplitude maximale (voir Photo 7-2). <p>Remarque : Eviter d'appuyer sur le ⊖ tournevis pendant le réglage de la vis, car ceci décalerait le capteur vers l'intérieur, rendant l'ajustement plus difficile.</p> <ul style="list-style-type: none"> ● En dernier lieu, retirer le filtre passe-bas et confirmer que la tension p-p du signal d'erreur d'alignement (ne pas insérer le filtre passe-bas 4kHz) ne varie pas fortement quand le capteur est déplacé à la première et à la dernière plage du disque. Si les niveaux divergent de 10% ou davantage, ré-ajuster le point d'amplitude d'erreur maximale en tournant sur la vis d'ajustement.

N° de étape	Réglage d'oscilloscope		Points d'essai	Points de réglage	Postes de contrôle / Spécifications de réglage	Procédure de réglage
	V	H				
						<p>Remonter le plateau du disque selon la procédure ci-après après avoir terminé l'ajustement de grincement.</p> <ol style="list-style-type: none"> 1. Retirer le disque et l'entretoise. 2. Tout en levant l'attache (marquée par B sur la Fig. 7-4) de la main droite, tenir le plateau de la main droite comme illustré par C et déplacer la base coulissante dans les armatures en résine dure sur la base de chargement, comme indiqué sur la Fig. 7-9 pour ré-insérer le plateau du disque. <p>A ce moment, prendre soin de tenir la bille d'acier en place par l'index de la main droite. Veiller également que le panneau avant ne soit pas endommagé par le roulement (dans la base coulissante), entrant en contact avec le panneau.</p> <ol style="list-style-type: none"> 3. Insérer la base coulissante de sorte qu'elle s'engage dans les armatures en résine dure à l'arrière de la base de chargement (voir Fig. 7-10). 4. Insérer à ferme le plateau.

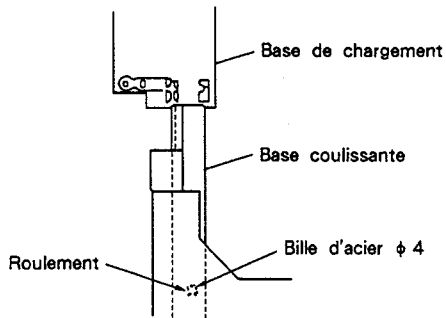


Fig. 7-9

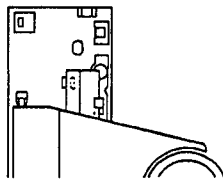


Fig. 7-10

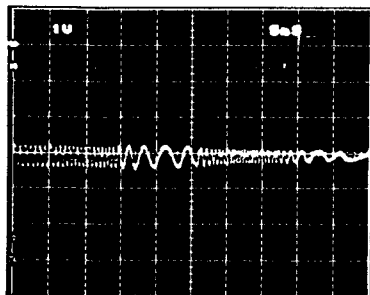


Photo 7-1
Point nul

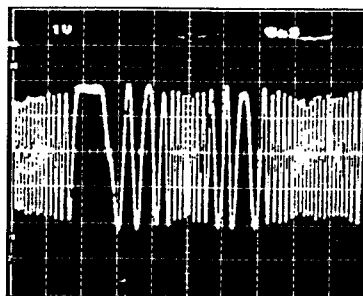


Photo 7-2
Amplitude maximale

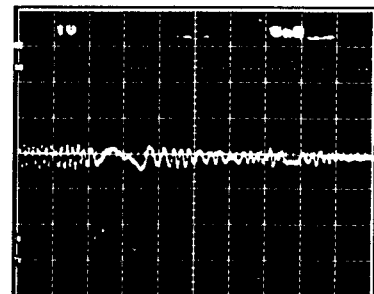
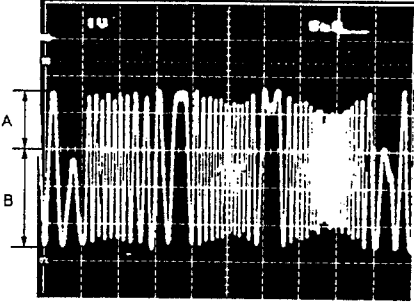
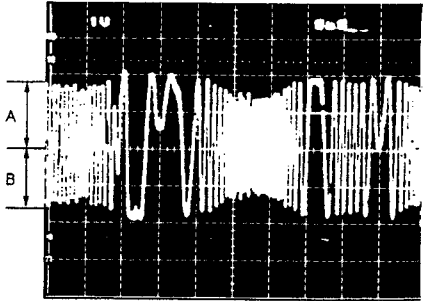
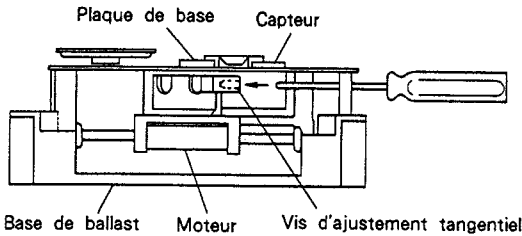
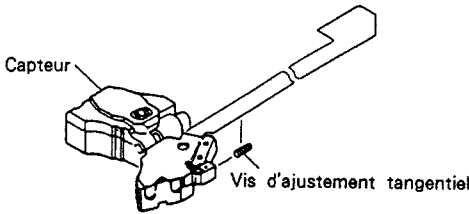


Photo 7-3
Ceci n'est pas la forme d'onde du point nul

N° de étape	Réglage d'oscilloscope		Points d'essai	Points de réglage	Postes de contrôle / Spécifications de réglage	Procédure de réglage
	V	H				
6 Réglage d'équilibre d'erreur d'alignement						
	0,5V/div	5msec/div	TP1 Broche 2 (TRK. ERR)	VR5 (TRK. BAL)		<ul style="list-style-type: none"> ● Installer le disque d'essai. ● Régler l'appareil en mode d'essai (voir page 44). ● Raccorder le câble MANUAL SEARCH FWD JP pour amener le capteur au centre du disque. ● Appuyer sur les touches TRACK FWD (▷▷) et PLAY (▷) en séquence pour faire tourner le disque. ● Observer TP1 broche 2 TRK.ERR (erreur d'alignement) sur l'oscilloscope et régler VR5 TRK. BAL (équilibre d'alignement) pour éliminer les éléments DC du signal d'erreur d'alignement.
					 <p>A ≠ B</p> <p>Photo 7-4 Eléments DC mêlés au signal</p>	 <p>A = B</p> <p>Photo 7-5 Eléments DC éliminés</p>
7 Réglage tangentiel (Procéder à l'ajustement après le retrait du bloc du mécanisme, ou après le retrait de l'assemblage AUDIO BOARD à l'arrière.)						
					<ul style="list-style-type: none"> ● Régler l'appareil en mode d'essai (voir page 44). ● Ouvrir le plateau et installer le disque d'essai. ● Raccorder le câble MANUAL SEARCH FWD JP pour amener le capteur au centre du disque. ● Insérer une clé hexagonale par l'orifice de la vis d'ajustement tangentiel par l'arrière du mécanisme. ● Refermer le plateau. <p>Remarque : Ne pas se servir d'une clé hexagonale en L, mais une comme illustré sur la gauche. L'emploi d'une clé hexagonale en L pourrait relâcher le plateau [voir page 48 5'. Réglage du grincement (2).]</p> <ul style="list-style-type: none"> ● Appuyer sur les touches TRACK FWD (▷▷) et PLAY (▷) en séquence pour fermer les servos (le témoin PAUSE s'allume). 	
						
	Fig. 7-11					

N° de étape	Réglage d'oscilloscope		Points d'essai	Points de réglage	Postes de contrôle / Spécifications de réglage	Procédure de réglage
	V	H				
		200nsec / div	TP1 Broche 1 Sortie RF	Vis d'ajustement tangentiel	Mire la plus nette possible	<ul style="list-style-type: none"> ● Observer TP1 broche 1 (sortie RF) sur l'oscilloscope et agir sur la vis d'ajustement tangentiel pour obtenir la mire la plus nette possible. ● Quand toute la forme d'onde devient claire, se concentrer sur la netteté des lignes fines, formant un losange au centre de la mire (voir Photo 7-8). Régler jusqu'à ce que les lignes fines sur les quatre côtés du losange soient bien définies et denses, comme illustré sur la Photo 7-6. <p>Remarque : Se servir d'une clé hexagonale pour lever légèrement le capteur pendant cet ajustement.</p>

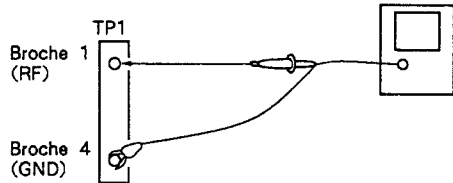
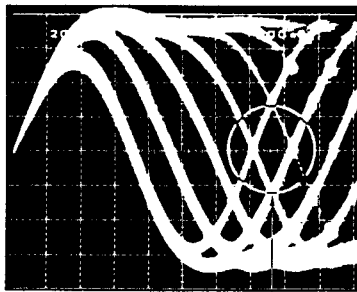
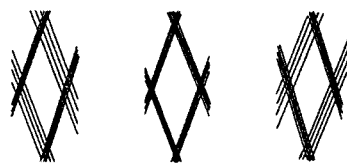


Fig. 7-12



Concentre sur la netteté du losange



Insatisfaisant Optimal Insatisfaisant

Photo 7-6

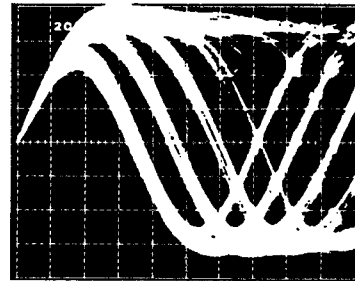


Photo 7-7

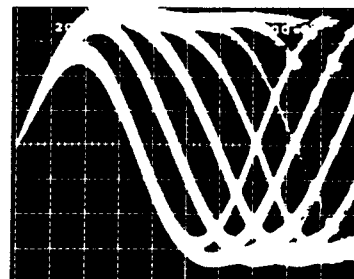


Photo 7-8

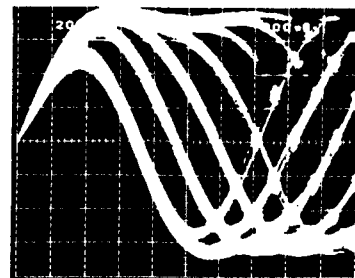
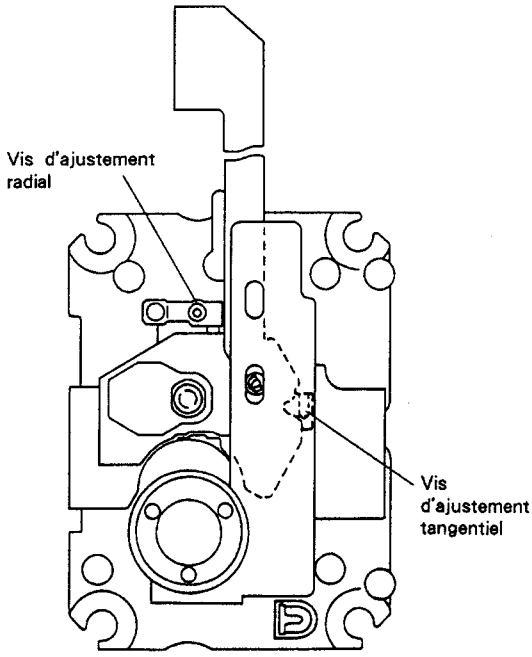
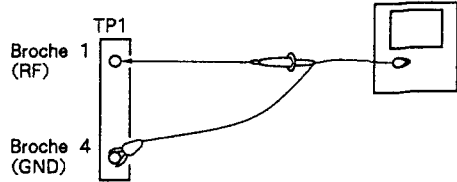


Photo 7-9

N° de étape	Réglage d'oscilloscope		Points d'essai	Points de réglage	Postes de contrôle / Spécifications de réglage	Procédure de réglage
	V	H				
8	Réglage radial					
			TP1 Broche 1 (Sortie RF)	Vis d'ajustement radial	Mire la plus nette possible	<p>Remonter le plateau du disque selon la procédure ci-après après avoir terminé l'ajustement de grincement.</p> <p>Remarque : Se reporter à la page 48, 5'. Réglage du grincement (2) au sujet du retrait du plateau du disque.</p> <ul style="list-style-type: none"> ● Installer le disque d'essai. ● Placer l'appareil en mode d'essai (Voir page 44). ● Raccorder le câble MANUAL SEARCH FWD JP pour amener le capteur au centre du disque, de façon que la vis d'ajustement tangentiel puisse être vue d'en haut (voir Fig. 7-11). ● Appuyer sur les touches TRACK FWD (▷▷) et PLAY (▷) en séquence pour fermer les servos (le témoin PAUSE s'allume). ● Observer TP1 broche 1 (sortie RF) sur l'oscilloscope et agir sur la vis d'ajustement radial pour obtenir la mire la plus nette possible. ● Quand toute la forme d'onde devient claire, se concentrer sur la netteté des lignes fines, formant un losange au centre de la mire (voir Photo 7-8). Régler jusqu'à ce que les lignes fines sur les quatre côtés du losange soient bien définies et denses, comme illustré sur la Photo 7-6. ● Procéder deux fois ou plus à l'ajustement tangentiel et à l'ajustement radial alternativement. ● Lorsque l'ajustement est terminé, replacer le plateau du disque (voir page 50).
				 <p>Fig. 7-13</p>		 <p>Fig. 7-14</p>

N° de étape	Réglage d'oscilloscope		Points d'essai	Points de réglage	Postes de contrôle / Spécifications de réglage	Procédure de réglage
	V	H				
9	Réglage de gain de mise au point					
	20mV/div CH1 (X) 5mV/div CH2 (Y) (sonde 10 : 1)		Axe des X : TP1 Broche 5 (FCS. IN) Axe des Y : TP1 Broche 6 (FCS. ERR)	VR3 (FCS. GAN)	Différence de phase de 90°	<ul style="list-style-type: none"> ● L'alimentation étant coupée (POWER OFF), raccorder l'oscillateur comme illustré sur la Fig. 7-15. ● Régler l'appareil en mode de lecture normale. ● Mettre l'oscillateur sous tension (ON) et le régler pour fournir un signal de 1,2kHz 1Vp-p. <p>Remarque : Certains oscillateurs déchargent une tension DC lors de leur mise sous tension. Par conséquent, il est conseillé de connecter l'oscillateur après l'avoir mis sous tension.</p> <ul style="list-style-type: none"> ● Ajust VR3 FCS. GAN (gain de mise au point) de sorte que la figure de Lissajou devienne un cercle horizontal (différence de phase de 90°).

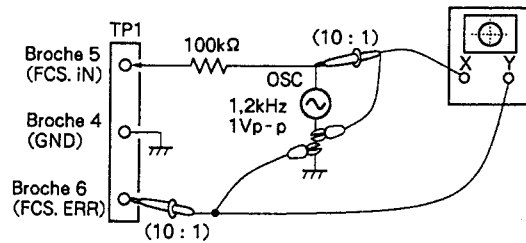


Fig. 7-15

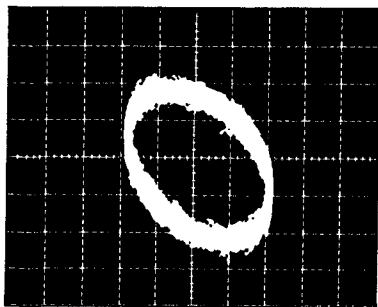


Photo 7-10
Gain sur-compensé

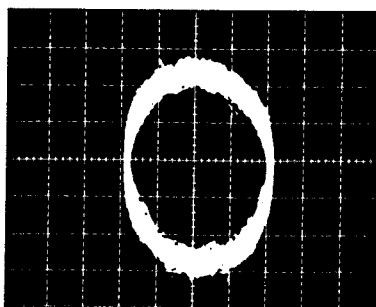


Photo 7-11
Gain optimal

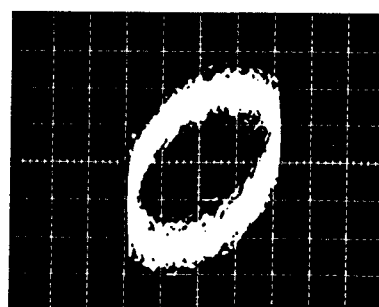


Photo 7-12
Gain sous-compensé

N° de étape	Réglage d'oscilloscope		Points d'essai	Points de réglage	Postes de contrôle /Spécifications de réglage	Procédure de réglage
	V	H				
10	Réglage de gain d'alignement					
	50mV/div CH1 (X) 5mV/div CH2 (Y) (sonde 10 : 1)	Axe des X : TP1 Broche 3 (TRK. IN) Axe des Y : TP1 Broche 2 (TRK. ERR)	VR3 (TRK. GAN)	Difference de phase de 90°	<ul style="list-style-type: none"> ● L'alimentation étant coupée (POWER OFF), raccorder l'oscillateur comme illustré sur la Fig. 7-16. ● Régler l'appareil en mode de lecture normale. ● Mettre l'oscillateur sous tension (ON) et le régler pour fournir un signal de 1,2kHz 2Vp-p. <p>Remarque : Certains oscillateurs déchargent une tension DC lors de leur mise sous tension. Par conséquent, il est conseillé de connecter l'oscillateur après l'avoir mis sus tension.</p> <ul style="list-style-type: none"> ● Ajuster VR4 TRK. GAN (gain d'alignement) de sorte que la figure de Lissajou devienne un cercle horizontal (différence de phase de 90°) 	

Fig. 7-16

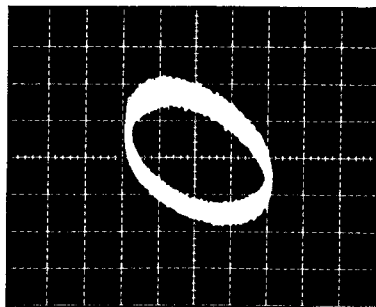


Photo 7-13
Gain sur-compensé

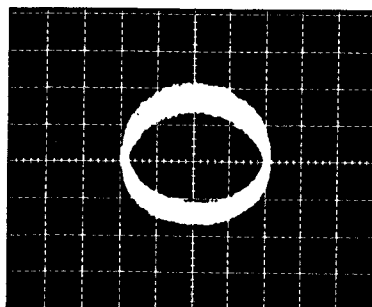


Photo 7-14
Gain optimal

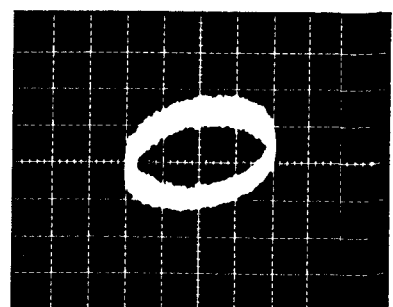


Photo 7-15
Gain sous-compensé

N° de étape	Réglage d'oscilloscope		Points d'essai	Points de réglage	Postes de contrôle / Spécifications de réglage	Procédure de réglage
	V	H				
11	Réglage de fréquence libre VCO					
			TP2 Broche 2 (PLCK)	VR8 (VCO. ADJ)	4,275 ± 0,025MHz	<ul style="list-style-type: none"> ● Régler l'appareil en mode d'essai (voir page 44). ● Court-circuiter l'ensemble et le cavalier de masse (GND) à l'aide d'un ⊖ tournevis ou d'un outil analogue (voir Fig. 7-17). ● Raccorder un fréquencemètre, capable de mesurer des fréquences de 10MHz et audelà, sur TP2 broche 2 (PLCK). ● Ajuster VR8 (ajustement VCO) de sorte que la lecture du fréquencemètre devienne 4,275 ± 0,025MHz.
12	Méthode de confirmation du caractère S (erreur de mise au point)					
			TP1 Broche 6 (FCS. ERR)			<ul style="list-style-type: none"> ● Régler l'appareil en mode d'essai (voir page 44). ● Mettre TP1 broche 5 FCS.IN (gain de mise au point) à la masse (GND). ● Observer la sortie de forme d'onde à TP1 broche 6 FCS.ERR (erreur de mise au point) quand la TRACK FWD (▷▷) est actionnée.

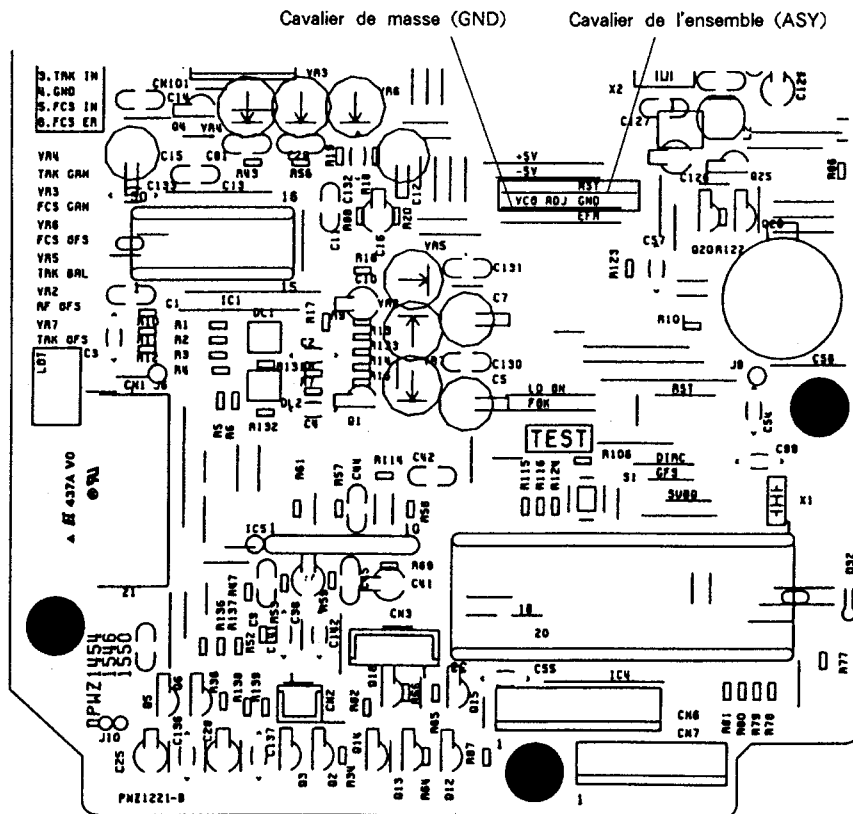
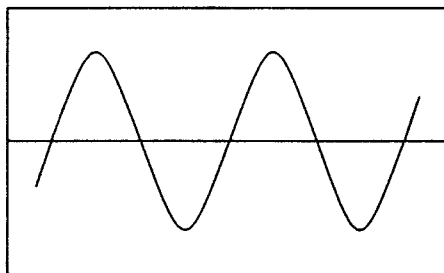


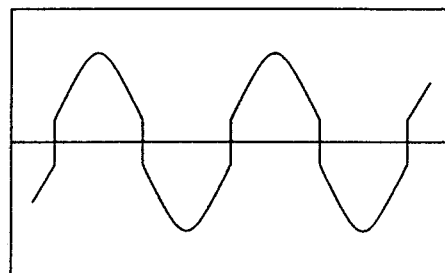
Fig. 7-17 Position des cavaliers des ASY et GND

N° de étape	Réglage d'oscilloscope		Points d'essai	Points de réglage	Postes de contrôle / Spécifications de réglage	Procédure de réglage
	V	H				
13	Réglage de MSB					
	5mV/div	0.2msec / div	JA1 Borne LINE OUTPUT (canal gauche)	VR506	Onde sinusoidale	<ul style="list-style-type: none"> ● Régler l'appareil en mode de lecture normale. ● Reproduire la piste 20 (-60dB, 1kHz, canal gauche, canal droit du disque d'essai YEDS-7). Raccorder l'oscilloscope au canal gauche de la borne LINE OUTPUT (JA1) et observer la forme d'onde de la sortie audio. ● Ajuster VR506 MSB (canal gauche) de sorte que l'onde sinusoidale apparaisse sur l'oscilloscope. ● Ajuster VR507 (canal droit) de la même manière.
			JA1 Borne LINE OUTPUT (canal droit)	VR507	Onde sinusoidale	

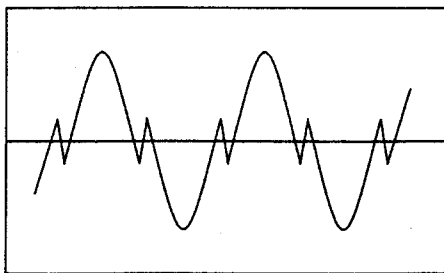
● Forme d'onde de la distorsion de croisement zéro



OK



NG



NG

7. AJUSTE

A continuación se of recen los ajustes para esta unidad. Estos ajustes deberán realizarse en el orden indicado.

● Ajustes e ítemes de comprobación

1. Ajuste de la desviación de error de seguimiento (VR7), enfoque (VR6) y desviación de RF (VR2).
2. Ajuste del nivel de RF (VR1)
3. Comprobación de la energía del diodo láser (LD)
4. Comprobación de la sincronización el servo del enfoque y del eje
5. Ajuste de retícula
6. Ajuste del equilibrio de error de seguimiento (VR5)
7. Ajuste tangencial
8. Ajuste radial
9. Ajuste de la ganancia de enfoque (VR3)
10. Ajuste de la ganancia de seguimiento (VR4)
11. Ajuste de la frecuencia de oscilación libre del oscilador controlade por tensión (VCO) (VR8)
12. Método para confirmar el carácter S (error de enfoque)
13. Ajuste de MSB (VR506, VR507)

● Equipos de medición

1. Osciloscopio de doble traza
2. Medidor de enería óptica
3. Disco de prueba (YEDS - 7), disco de 8 cm
4. Filtro de ajuste de ganancia de bucle
5. Generador de señales
6. Frecuencímetro
7. Otros equipos de medición regulares

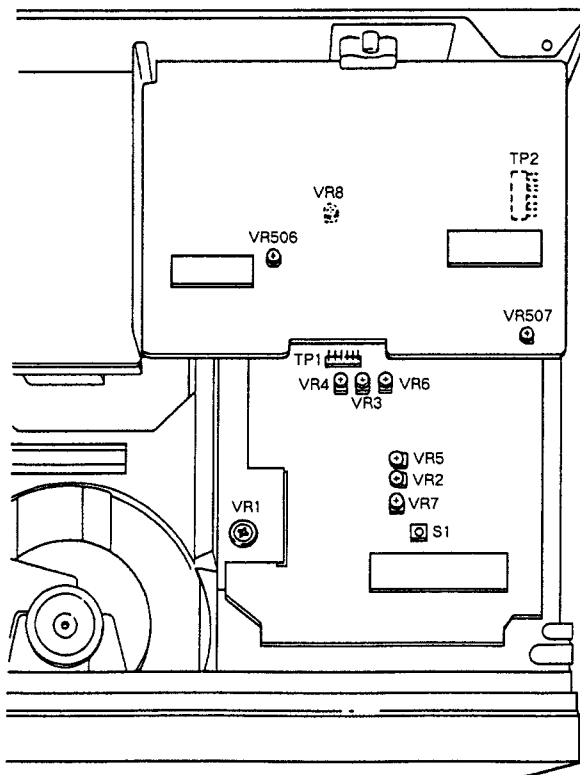
● Modo de prueba

Activación y desactivación del mode de prueba

- ① Para activar el mode de prueba, ponga en ON el interruptor de alimentación (S301) con el interruptor de modo de prueba (S1) en ON.
- ② El modo de prueba se desactivará poniendo el interruptor de alimentación en OFF.

Las funciones de las teclas en el modo de prueba se describen en la tabla 7-1.

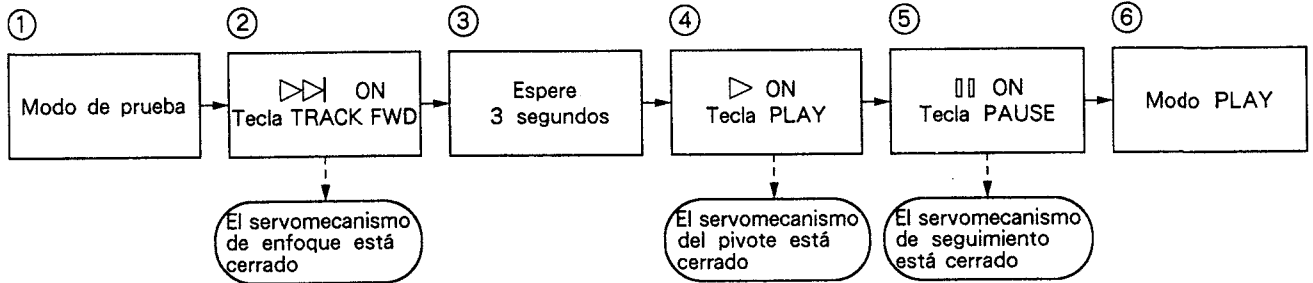
Punto de ajuste



En el modo de prueba, enfoque, seguimiento y eje servos deberán abrir y cerrarse individualmente. Por consiguiente, los servos deberán cerrarse en la secuencia apropiada (secuencia en serie) a fin de poner la máquina en el modo de reproducción normal. Tenga en cuenta además que la máquina no entrará en el modo de reproducción cuando haya presionado la tecla PAUSE (||).

Por ejemplo, para cambiar del modo de parada al de reproducción, tendrá que presionar las teclas de función en el orden siguiente :

* En el modo de prueba, los servos deberán operarse en secuencia en serie.



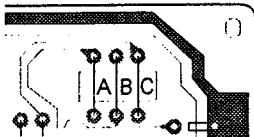
• Funciones de las teclas en el modo de prueba

Símbolo	Nombre de la tecla	Función en el modo de prueba	Descripción
▷▷	TRACK FWD	Cierre del servo de enfoque	Activa el diodo lasér, y eleva y hace descender el actuador de enfoque para cerrar el servo de enfoque.
▷	PLAY	Cierre del servo del eje	Cierra el servo en el modo CLV-A después de impulsar el motor del eje.
	PAUSE	Cierre/apertura del servo de seguimiento	Actúa como conmutador : cierra el servo de seguimiento y activa el modo de reproducción cuando se presiona (suponiendo que los servos de enfoque y del eje estén cerrados), momento en el que se encenderá el indicador PAUSE ; y abre el servo de seguimiento cuando vuelve a presionarse.
□	STOP	Parada	Para todos los servos y devuelve el sistema a su estado inicial.
△	OPEN/CLOSE	Apertura/cierre de la bandeja del disco	Abre cierra la bandeja del disco. Sin embargo, el captor no regresa a su soporte en OPEN (apertura), y permanece estacionario en CLOSE (cierre).

Tabla 7-1

● Cuando realice la búsqueda manual

* La función de la tecla MANUAL SEARCH se simula mediante los puentes de conexión (JP) A, B y C del conjunto FUNCTION BOARD.



- Conjunto FUNCTION BOARD, visto desde el lado de las pistas.
- Conexión de los puentes C y B = MANUAL SEARCH REV.
- Conexión de los puentes A y B = MANUAL SEARCH FWD.

	Función	Descripción
MANUAL SEARCH REV	Retroceso del carro (se mueve hacia adentro)	Mueve el carro rápidamente (1cm/s) hacia la pista más interior. Tenga cuidado para no moverlo demasiado ya que no hay dispositivo de seguridad para detener el carro.
MANUAL SEARCH FWD	Avance del carro (mueve el carro hacia afuera)	Mueve el carro rápidamente (1cm/s) hacia la pista más exterior. Tenga cuidado para no moverlo demasiado ya que no hay dispositivo de seguridad para detener el carro.

N° de paso	Ajuste del osciloscopio		Puntos de prueba	Puntos de ajuste	Items de comprobación/ Especificaciones de ajuste	Procedimiento de ajuste
	V	H				
1 Ajuste de la desviación de error de seguimiento, enfoque y desviación de RF						
			TP1 Patilla 2 (TRK. ERR)	VR5 (TRK. BAL) VR7 (TRK. OFS)	Desviación de error de seguimiento 45 é 0V ± 50mV	<ul style="list-style-type: none"> ● Ponga la unidad en el modo de prueba (consulte la página 58). ● Ponga VR5 TRK. BAL (equilibrio de seguimiento) en una posición aproximadamente 45 é a la izquierda del centro*. ● Ajuste VR7 TRK. OFS (desviación de seguimiento) de forma que la TRKG. ERR (tensión de error) de seguimiento de la patilla 2 de TP1 sea de 0V ± 50mV. ● Ajuste VR6 FCS. OFS (desviación de enfoque) de forma que la tensión de FOCS. ERR (error de enfoque) en pa patilla 6 de TP1 sea de 100mV ± 50mV. ● Ajuste VR2 RF. OFS (desviación de RF) de forma que la tensión de salida de RF de la patilla de TP1 sea de 100mV ± 50mV. <p>Nota : Cuando ajuste la desviación de seguimiento, realice siempre "6. Ajuste del equilibrio de error de seguimiento".</p>
			TP1 Patilla 6 (FCS. ERR)	VR6 (FCS. OFS)	Desviación de error de enfoque 0V ± 50mV	
			TP1 Patilla 1 (RF OUTPUT)	VR2 (RF. OFS)	Desviación de RF 100mV ± 50mV	
2 Ajuste del nivel de RF						
			TP1 Patilla 1 (RF OUTPUT)	VR1 (Alimentación de láser)	1,5Vp-p \pm 0,2 V	<ul style="list-style-type: none"> ● Ponga la unidad en el modo de prueba (consulte la página 58). ● Instale el disco de prueba y conecte el osciloscopio a la patilla 1 de TP1 (salida de RF), ponga en reproducción el disco de prueba, y mida la tensión de pico a pico de la forma de onda de RF. ● Ajuste VR1 (alimentación de láser) de forma que la tensión sea 1,5Vp-p \pm 0,2 V.
3 Comprobación de la energía del diodo láser (LD)						
				Comprobación	Menos de : 0,13mW	<ul style="list-style-type: none"> ● Ponga la unidad en el modo de prueba (consulte la página 58). ● Presione la tecla TRACK FWD (▷▷) para activar el diodo láser (LD). ● Coloque el modificador de potencia óptico directamente encima del objetivo y confirme que la potencia LD sea menos de 0,13mW.
4 Comprobación de la sincronización el servo del enfoque y del eje						
	0,5V/div	100msec /div	TP1 Patilla 1 (Salida de RF)		La señal de RF sale Giro en sentido de avance (hacia la derecha)	<ul style="list-style-type: none"> ● Instale el disco de prueba. ● Ponga la unidad en el modo de prueba (consulte la página 58). ● Conecte el JP MANUAL SEARCH FWD para mover el captor hasta el centro del disco. ● Observe la salida de la patilla 1 de TP1 (salida de RF) en el osciloscopio. Compruebe si la señal de RF sale después de presionar la tecla TRACK FWD (▷▷). ● Presione la tecla PLAY (▷) y compruebe si el disco gira a velocidad constante (aprox. 300 rpm cerca del centro del disco) en sentido de avance (hacia la derecha); el disco puede no girar o hacerlo hacia la izquierda.

N° de paso	Ajuste del osciloscopio		Puntos de prueba	Puntos de ajuste	Items de comprobación/ Especificaciones de ajuste	Procedimiento de ajuste
	V	H				
5 Ajuste de retícula (1) (Cuando emplee un disco de 8 cm)						
						<p>Nota : Este ajuste podrá realizarse empleando un disco de 8 cm que posea los hoyos dentro de un diámetro de 75 mm.</p> <ul style="list-style-type: none"> ● Ponga la unidad en el modo de prueba (consulte la página 58). ● Conecte el JP MANUAL SEARCH FWD para mover el captor hasta el centro del disco, de forma que el tornillo de ajuste de retícula de dicho captor pueda verse a través del orificio ovalado (uno de los orificios ovalados que está cerca del motor del eje central) de la placa base del servomecanismo. ● Como se muestra en la Fig. 7-1, inserte un ⊖ destornillador (ranurado) desde la parte superior del mecanismo y compruebe si puede girar el tornillo de ajuste de retícula. ● Instale el disco de prueba. ● Presione secuencialmente las teclas TRACK FWD (▷▷) y PLAY (▷) para cerrar los servos de enfoque y del eje (no cierre el servo de seguimiento). ● Observe la forma de onda de TRK. ERR (error de seguimiento) de la patilla 2 de TP1 en el osciloscopio, insertando un filtro de paso bajo de 4 kHz (consulte la Fig. 7-2).
						<p>● Inserte un ⊖ destornillador en el orificio del tornillo de ajuste de retícula, gire y halle el punto nulo (consulte la foto 7-1).</p> <p>● A continuación, gire lentamente ⊖ destornillador HACIA LA IZQUIERDA desde el punto nulo hasta que la forma de onda (señal de error de seguimiento) alcance la máxima amplitud (consulte la foto 7-2).</p> <p>Nota : Tenga cuidado, porque si inserta el destornillador a la fuerza, la unidad captora se elevará.</p> <p>● Por último, confirme que no haya gran fluctuación la tensión de pico a pico de la señal de error de seguimiento (no inserte el filtro de paso bajo de 4 kHz de corre) cuando el captor se desplace de la pista más interior a la más exterior del disco. Si la diferencia es mayor del 10 % o más, vuelva a girar el tornillo de ajuste de retícula y ajuste la señal de error al máximo.</p>
	0,5V/div	5msec/div	TP1 Patilla 2 (TRK. ERR)	Tornillo de ajuste de retícula Tornillo de ajuste de retícula	Punto nulo Amplitud máxima	
						<p>Fig. 7-2</p>

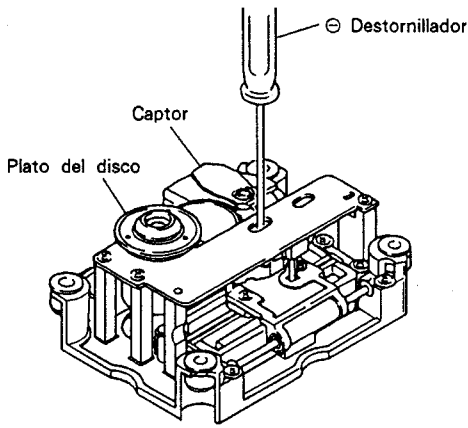


Fig. 7-1

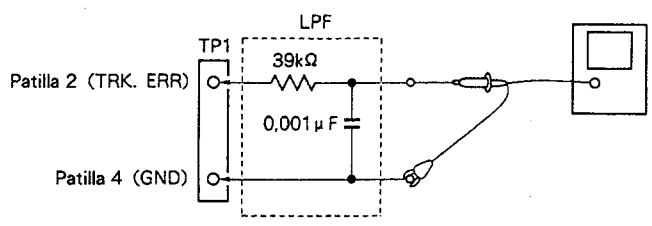
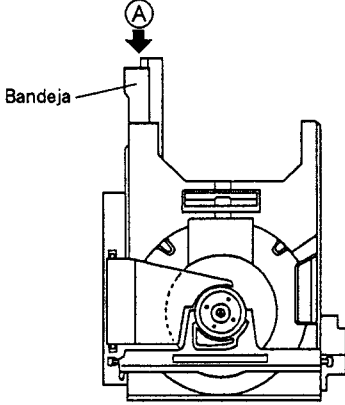
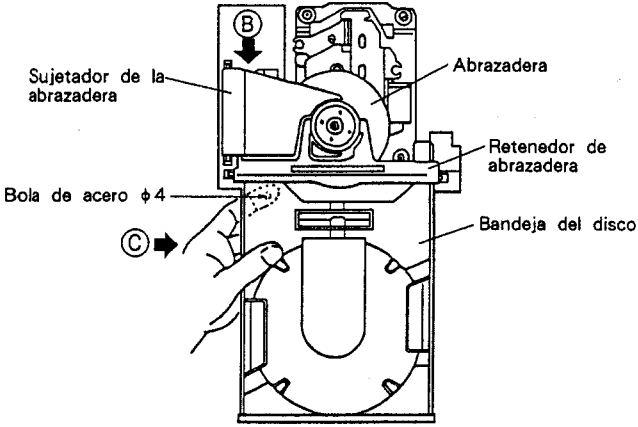
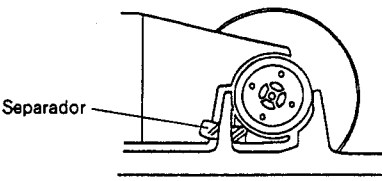
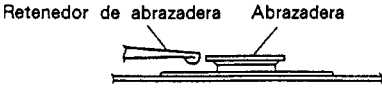


Fig. 7-2

N° de paso	Ajuste del osciloscopio		Puntos de prueba	Puntos de ajuste	Items de comprobación/ Especificaciones de ajuste	Procedimiento de ajuste
	V	H				
5'	Ajuste de retícula (2) (Cuando no disponga de disco de 8 cm)					
 <p>Fig. 7-3</p>			<p>Este ajuste se realiza cuando no haya disco de 8 cm disponible, y el ajuste de retícula (1) no pueda realizarse. Para realizar este ajuste, extraiga la bandeja del disco.</p> <ul style="list-style-type: none"> ● Extracción de la bandeja del disco. <ol style="list-style-type: none"> 1. Presione el borde posterior del bastidor, marcado con A en la Fig. 7-3, (*1) tirando de la bandeja del disco hasta la posición en la que agarre, mostrada en la Fig. 7-4. (*1) Si presiona el borde posterior del bastidor A, se libera la abrazadera de discos. Si continua presionando después de que se haya liberado completamente la abrazadera, sale eyectada la bandeja del discos. 2. Tirando del soporte de abrazadera B (consulte la Fig. 7-4) hacia arriba con la mano derecha, sujeta la bandeja como se indica en C con la mano izquierda y tire de ella hacia afuera. Tenga cuidado para que no caiga la bola de acero $\phi 4$ (recomendamos sujetar la bola en su lugar con el dedo índice de la mano izquierda al sacar la bandeja). 			
 <p>Fig. 7-4</p>						
 <p>Fig. 7-5</p>						
 <p>Fig. 7-6</p>						

N° de paso	Ajuste del osciloscopio		Puntos de prueba	Puntos de ajuste	Ítems de comprobación/ Especificaciones de ajuste	Procedimiento de ajuste
	V	H				
						<ul style="list-style-type: none"> ● Ponga la unidad en el modo de prueba (consulte la página 58). ● Conecte el JP MANUAL SEARCH FWD para mover el captor hasta el centro del disco, de forma que el tornillo de ajuste de retícula de dicho captor pueda verse a través del crificio ovalado (uno de los orificios ovalados que está cerca del motor del eje central) de la placa base del servomecanismo. ● Como se muestra en la Fig. 7-7, inserte un ⊖ destornillador (ranurado) desde la parte superior del mecanismo y compruebe si puede girar el tornillo de ajuste de retícula. ● Instale el disco de prueba, asegúrese de insertar un separador de 3-5 mm (si no dispone de separador emplee una llave hexagonal) entre el sujetador de abrazadera y el retenedor de abrazadera, como se muestra en la Fig. 7-5. ● Confirme que la abrazadera y el retenedor de la misma no estén en contacto entre si (Fig. 7-6). ● Presione secuencialmente las teclas TRACK FWD (▷▷) y PLAY (▷) para cerrar los servos de enfoque y del eje (no cierre el servo de seguimiento). ● Inserte un filtro de paso bajo de 4 kHz de corte entre el osciloscopio y la patilla 3 (TRK. ERR) y 5 (GND) de TP1, como se muestra en la Fig.7-8, y observe la forma de onda de la patilla 3 de TP1 (error de seguimiento) en el osciloscopio.
	0,5V/div	5msec /div	TP1 Patilla 2 (TRK. ERR)	Tornillo de ajuste de retícula Tornillo de ajuste de retícula	Punto nulo Amplitud máxima	<ul style="list-style-type: none"> ● Gire el tornillo de ajuste de retícula con el destornillador hasta encontrar el punto nulo (consulte la foto 7-1). ● A continuación, gire lentamente el ⊖ destornillador HACIA LA IZQUERDA de punto null y ajústelo hasta el punto en el que la forma de onda (señal de error de seguimiento) llegue por primera vez a su máxima amplitud (consulte la foto 7-2). <p>Nota: Evite aplicar excesiva presión al ⊖ destornillador cuando ajuste el tornillo. De lo contrario, el captor se moverá hacia adentro haciendo más difícil el ajuste.</p> <ul style="list-style-type: none"> ● Por último, desconecte el filtro de paso bajo y confirme que la tensión de pico a pico de la señal de error de seguimiento (no inserte el filtro de paso bajo de 4 kHz de corte) no varíe mucho cuando el captor se mueva de la pista más interior a la más exterior del disco. Si los niveles difieren en un 10% o más, reajuste el punto de error de amplitud máxima girando el tornillo de ajuste de retícula.

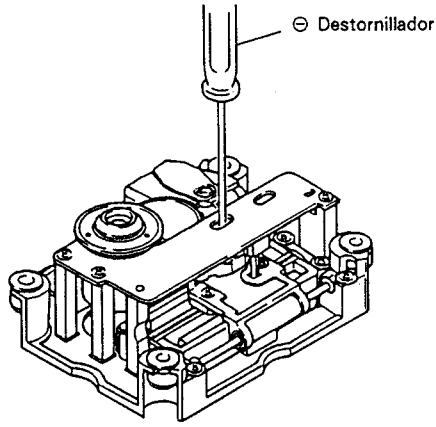


Fig. 7-7

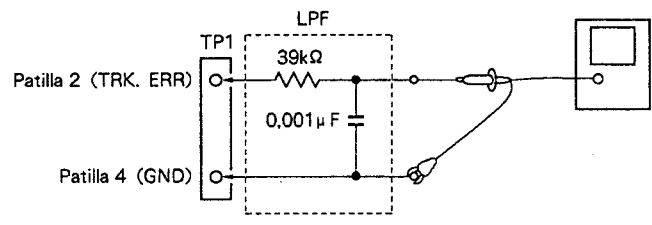


Fig. 7-8

N° de étape	Réglage d'oscilloscope		Points d'essai	Points de réglage	Postes de contrôle / Spécifications de réglage*	Procédure de réglage
	V	H				
						<p>Una vez finalizado el ajuste de retícula, vuelva a montar la bandeja del disco de acuerdo con el procedimiento siguiente.</p> <ol style="list-style-type: none"> 1. Extraiga el disco y el separador. 2. Levantando el sujetador de abrazadera (marcado con ⊕ en la Fig. 7-4) con la mano izquierda, sujete la bandeja con la mano izquierda como se indica en ⊙ y deslice la base deslizable en los acopladores de resina rígida de la base de carga como se muestra en la Fig. 7-9 para reinsertar la bandeja del disco. <p>En este momento, asegúrese de sujetar la bola de acero en su lugar con el dedo índice de la mano izquierda. Además, tenga cuidado para no dañar el panel frontal con la base deslizable y el cojinete de boals de acero (de la base deslizable).</p> <ol style="list-style-type: none"> 3. Inserte la base deslizable de forma que encaje en los dos acopladores de resina rígida de la parte posterior de la base de carga (consulte la Fig. 7-10). 4. Inserte completamente la bandeja del disco.

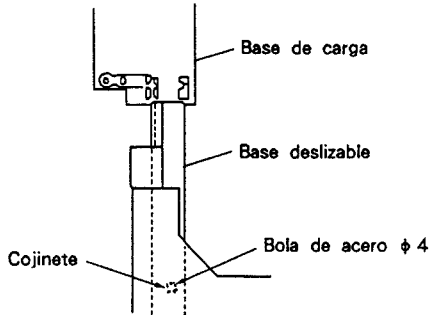


Fig. 7-9

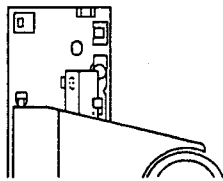


Fig. 7-10

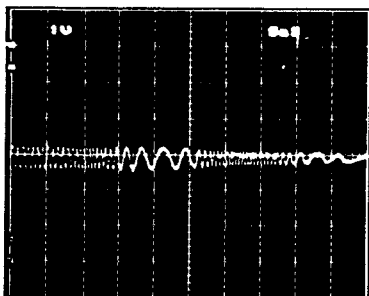


Foto 7-1
Punto cero

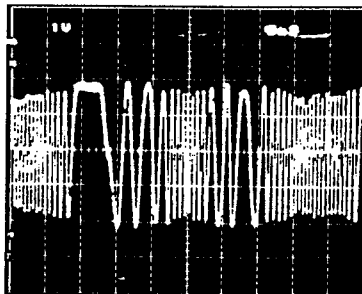


Foto 7-2
Amplitud máxima

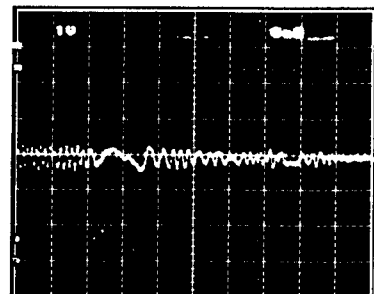
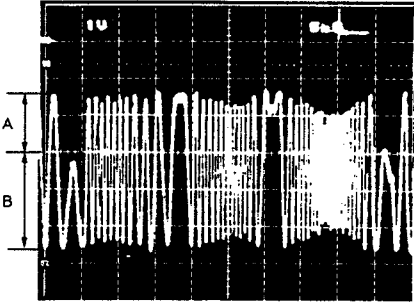
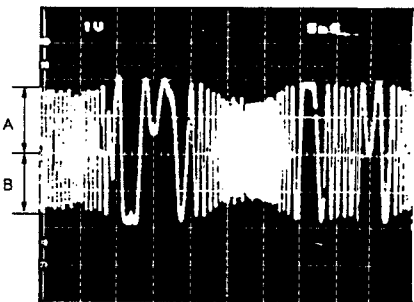
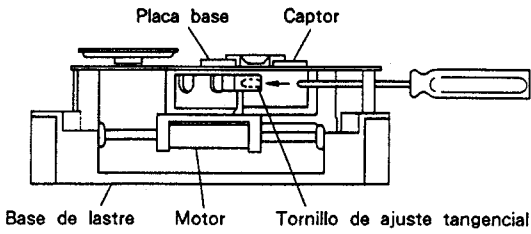


Foto 7-3
Forma de onda de un punto no cero

N° de paso	Ajuste del osciloscopio		Puntos de prueba	Puntos de ajuste	Items de comprobación/ Especificaciones de ajuste	Procedimiento de ajuste
	V	H				
6 Ajuste del equilibrio de error de seguimiento						
	0,5V/div	5msec /div	TP1 Patilla 2 (TRK. ERR)	VR5 (TRK. BAL)		<ul style="list-style-type: none"> ● Instale el disco de prueba. ● Ponga la unidad en el modo de prueba (consulte la página 58). ● Conecte el JP MANUAL SEARCH FWD para mover el captor hasta el centro del disco. ● Presione secuencialmente las teclas TRACK FWD (▶▶) y PLAY (▶) para hacer que el disco gire. ● Observe la forma de onda (error de seguimiento) de la patilla 2 (TRK.ERR) de TP1 en el osciloscopio, y ajuste VR5 TRK. BAL (equilibrio de seguimiento) para eliminar los elementos de CC de la señal de error de seguimiento.
					 <p>A ≠ B</p> <p>Foto 7-4 Elementos de CC mezclados con la</p>	 <p>A = B</p> <p>Foto 7-5 Elementos de CC eliminados</p>
7 Ajuste tangencial (Realice el ajuste después de extraer el bloque del mecanismo, o después de extraer el conjunto AUDIO BOARD de la parte posterior.)						
						<ul style="list-style-type: none"> ● Ponga la unidad en el modo de prueba (consulte la página 58). ● Abra la bandeja y instale el disco prueba. ● Conecte el JP MANUAL SEARCH FWD para mover el captor hasta el centro del disco. ● Inserte una llave hexagonal en la sección del tornillo de ajuste tangencial desde la parte posterior del mecanismo. ● Cierre la bandeja. <p>Note: No emplee una llave hexagonal en forma de L. Emplee una como la mostrada a la izquierda. Si emplea una llave hexagonal en forma de L Puede hacer que se afloje la bandeja [consulte la página 52 5'. "Ajuste de retícula (2)".</p> <ul style="list-style-type: none"> ● Presione secuencialmente las teclas TRACK FWD (▶▶) y PLAY (▶) para cerrar los servos (el indicador de PAUSE se encenderá).
						 <p>Fig. 7-11</p>

N° de étape	Réglage d'oscilloscope		Points d'essai	Points de réglage	Postes de contrôle / Spécifications dérèglage	Procédure de réglage
	V	H				
		200nsec / div	TP1 Patilla 1 Salida de RF	Tornillo de ajuste tangencial	Patrón ocular más nitido posible	<ul style="list-style-type: none"> ● Observe la forma de onda de la patilla 1 de TP1 (salida de RF) en el osciloscopio, y ajuste el tornillo de ajuste tangencial hasta lograr el patrón ocular más nitido posible. ● Cuando toda la forma de onda sea clara, concentre o aguce las líneas finas que forman el diamante en el centro del patrón ocular (consulte la foto 7-8). Ajuste hasta que las líneas finas de los cuatro lados del diamante queden nitidamente definidas y densas, como se muestra en la foto 7-6. <p>Nota : Emplee una llave hexagonal para levantar algo en captor cuando realice este ajuste.</p>

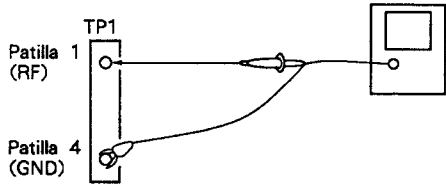
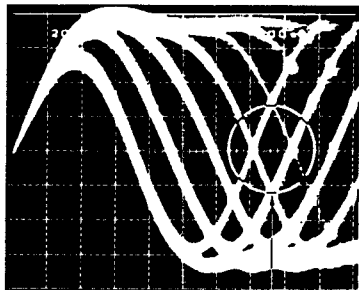
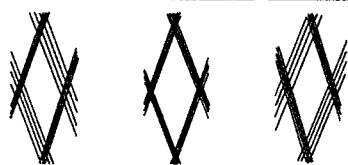


Fig. 7-12



Concentre o aguce este diamante.



No es óptimo óptimo No es óptimo

Foto 7-6

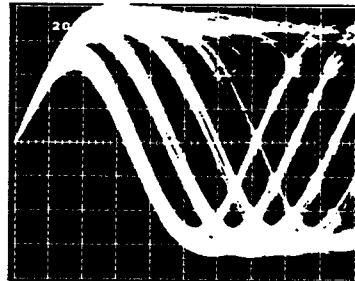


Foto 7-7

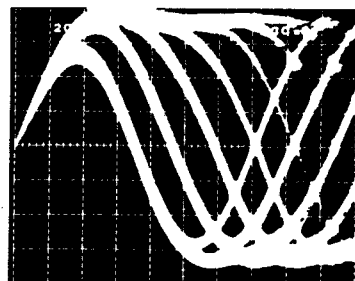


Foto 7-8

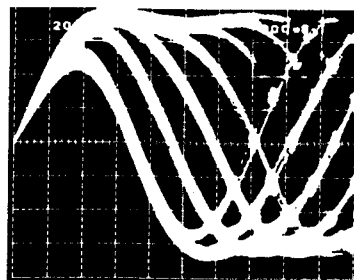


Foto 7-9

N° de paso	Ajuste del osciloscopio		Puntos de prueba	Puntos de ajuste	Items de comprobación/ Especificaciones de ajuste	Procedimiento de ajuste
	V	H				
8	Ajuste radial					
			TP1 Patilla 1 (salida de RF)	Tornillo de ajuste radial	Patrón ocular más nitido posible	<p>Antes de iniciar este ajuste, extraiga la bandeja del disco.</p> <p>Nota : Con respecto a la extraccion de la bandeja del disco, consulte la página 62, 5'. Ajuste de reticula (2).</p> <ul style="list-style-type: none"> ● Instale el disco prueba. ● Ponga la unidad en el modo de prueba (consulte la pagina 58). ● Conecte el JP MANUAL SEARCH FWD para mover el captor hasta el centro del disco, de forma que el tornillo de ajuste tangencial pueda verse desde la parte superior (consulte la Fig. 7-11). ● Presione secuencialmente las teclas TRACK FWD (▶▶) y PLAY (▶) para cerrar los servos (el indicador de PAUSE se encenderá). ● Observe la forma de onda de la patilla 1 de TP1 (salida de RF) en el osciloscopio, y ajuste el tornillo de ajuste radial hasta lograr el patrón ocular más nitido posible. (Fig. 7-13) ● Cuando toda la forma de onda sea clara, concentre o aguce las líneas finas que forman el diamante en el centro del patrón ocular (consulte la foto 7-8). Ajuste hasta que las líneas finas de los cuatro lados del diamante queden nitidamente definidas y densas, como se muestra en la foto 7-6. ● Realice el ajuste tangencial y el ajuste radial dos o más veces alternativamente. ● Cuando finalice el ajuste, vuelava a instalar la bandeja del disco (consulte la página 64).

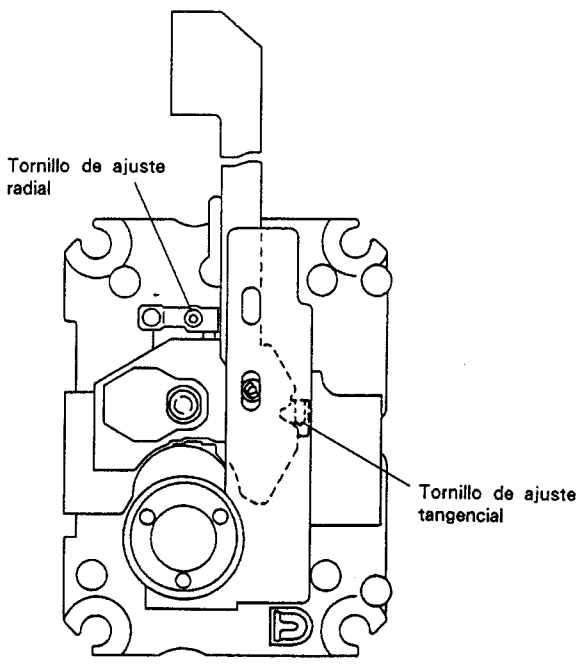


Fig. 7-13

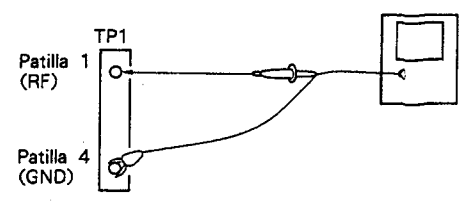


Fig. 7-14

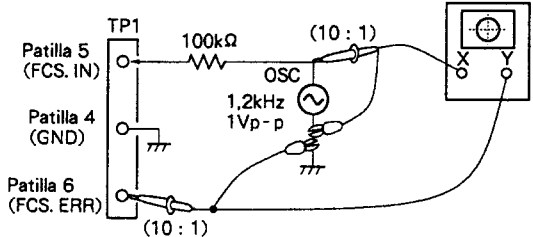
N° de paso	Ajuste del osciloscopio		Puntos de prueba	Puntos de ajuste	Items de comprobación/ Especificaciones de ajuste	Procedimiento de ajuste
	V	H				
9	Ajuste de la ganancia de enfoque					
	20mV/div CH1 (X) 5mV/div CH2 (Y) (sonda 10 : 1)	Eje X : TP1 Patilla 5 (FCS. IN) Eje Y : TP1 Patilla 6 (FCS. ERR)	VR3 (FCS. GAN)	Diferencia de fase de 90°	<ul style="list-style-type: none"> ● En el estado de POWER OFF (apagado), conecte el osciloscopio y el oscilador como se muestra en la Fig. 7-15. ● Ponga la unidad en el modo de reproducción (PLAY) normal. ● Conecte la alimentación del oscilador y ajuste su salida a una señal de 1,2kHz, 1Vp-p. <p>Nota : Algunos osciladores descargan una tensión CC cuando se conecta su alimentación. Pro lo tanto, se recomienda conectar el oscilador después de haber conectado su alimentación.</p> <ul style="list-style-type: none"> ● Ajuste VR3 FCS. GAN (ganancia de enfoque) de forma que la figura de Lissajous se convierta en un círculo horizontal (diferencia de fase de 90°). 	

Fig. 7-15

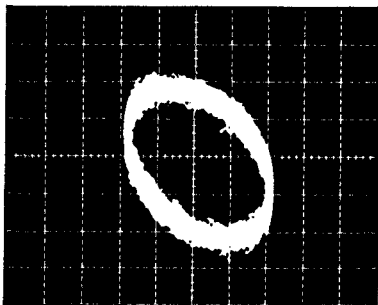


Foto 7-10
Ganancia sobrecompensada

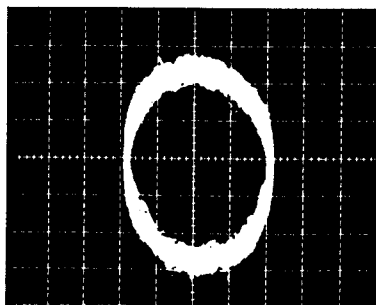


Foto 7-11
Ganancia óptima

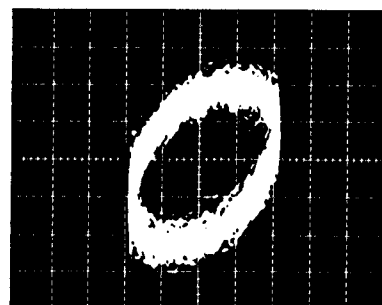


Foto 7-12
Ganancia subcompensada

N° de paso	Ajuste del osciloscopio		Puntos de prueba	Puntos de ajuste	Ítemes de comprobación/ Especificaciones de ajuste	Procedimiento de ajuste
	V	H				
10 Ajuste de la ganancia de seguimiento						
	50mV/div CH1 (X) 5mV/div CH2 (Y) (sonda 10 : 1)	Eje X : TP1 Patilla 3 (TRK. IN) Eje Y : TP1 Patilla 2 (TRK. ERR)	VR4 (TRK. GAN)	Diferencia de fase de 90°	<ul style="list-style-type: none"> ● En el estado de POWER OFF (apagado), conecte el osciloscopio y el oscilador como se muestra en la Fig. 7-16. ● Ponga la unidad en el modo de reproducción (PLAY) normal. ● Conecte la alimentación del oscilador y ajuste su salida a una señal de 1,2kHz, 2Vp-p. <p>Nota : Algunos osciladores descargan una tensión CC cuando se conecta su alimentación. Por lo tanto, se recomienda conectar el oscilador después de haber conectado su alimentación.</p> <ul style="list-style-type: none"> ● Ajuste VR4 TRK .GAN (ganancia de seguimiento) de forma que la figura de Lissajous se convierta en un círculo horizontal (diferencia de fase de 90°). 	

Fig. 7-16

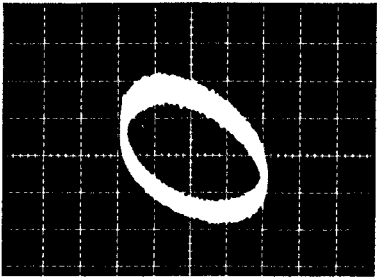


Foto 7-13
Ganancia sobrecompensade

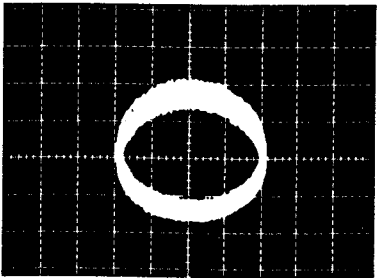


Foto 7-14
Ganancia óptima

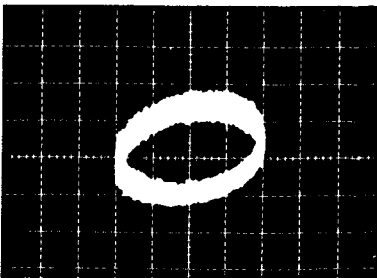


Foto 7-15
Ganancia subcompensade

N° de paso	Ajuste del osciloscopio		Puntos de prueba	Puntos de ajuste	Ítems de comprobación/ Especificaciones de ajuste	Procedimiento de ajuste
	V	H				
11	Ajuste de la frecuencia de oscilación libre del oscilador controlado por tensión (VCO)					
			TP2 Patilla 2 (PLCK)	VR8 (VCO. ADJ)	4,275 ± 0,025MHz	<ul style="list-style-type: none"> ● Ponga la unidad en el modo de prueba (consulte la página 58). ● Cortocircuite ASY y GND con un ⊖ destornillador a algún objeto similar (consulte la Fig. 7-17). ● Conecte un frecuencímetro capaz de medir frecuencias de más 10MHz a la patilla 2 de TP2. ● Ajuste VR8 (ajuste del VCO) hasta que el frecuencímetro indique 4,275 ± 0,025MHz.
12	Método para confirmar el carácter S (error de enfoque)					
			TP1 Patilla 6 (FCS. ERR)			<ul style="list-style-type: none"> ● Ponga la unidad en el modo de prueba (consulte la página 58). ● Conecte a masa la patilla 5 de TP1 (ganancia de enfoque). ● Observe la forma de onda de salida de la patilla 6 FCS.ERR de TP1 (error de enfoque) al presionar la tecla TRACK FWD (▷▷).

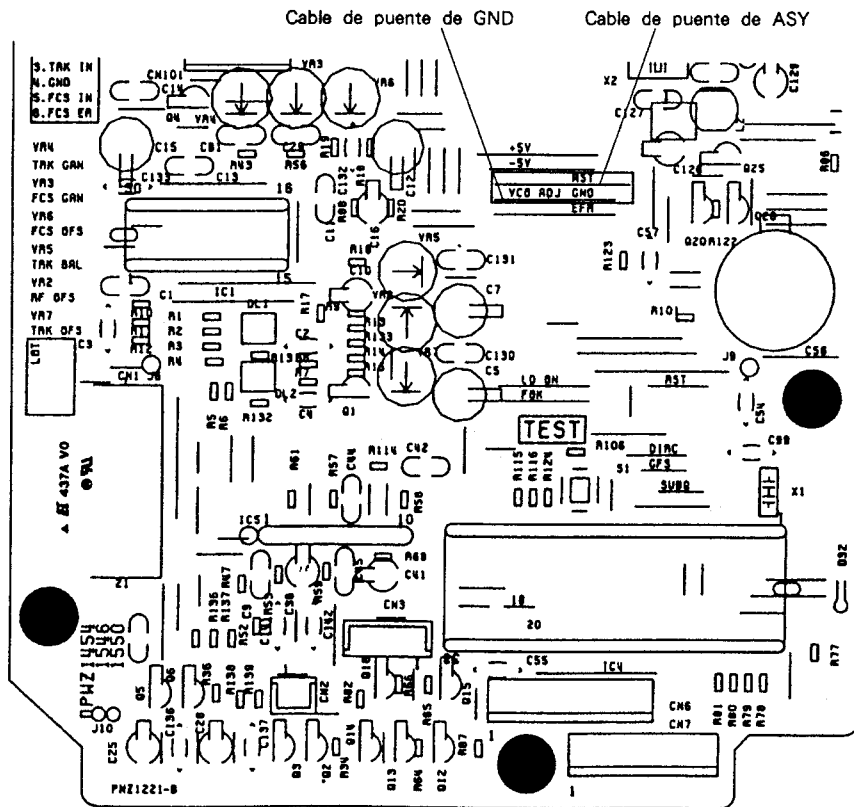
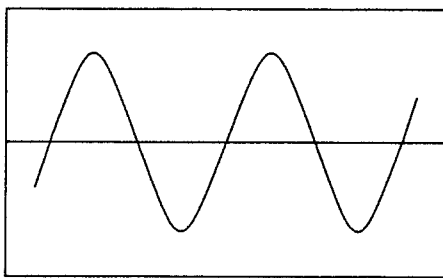


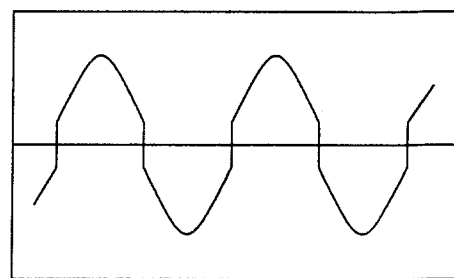
Fig. 7-17 Posición del cable de puente de ASY y GND

N° de paso	Ajuste del osciloscopio		Puntos de prueba	Puntos de ajuste	Items de comprobación/ Especificaciones de ajuste	Procedimiento de ajuste
	V	H				
13 Ajuste de MSB						
	5mV/div	0.2msec /div	JA1 terminal LINE OUTPUT (canal derecho)	VR506	Onda senoidal	<ul style="list-style-type: none"> ● Ponga la unidad en el modo de reproducción normal. ● Reproduzca la canción 20 (-60 dB, 1kHz, canales izquierdo y derecho) del disco de prueba (YEDS-7). Conecte el osciloscopio a el canal derecho del terminal LINE OUTPUT (JA1), y observe la forma de onda de salida de audio. ● Ajuste VR506 MSB (canal derecho) hasta obtener una forma de onda senoidal en el osciloscopio. ● Ajuste VR507 (canal izquierdo) de la misma forma.
			JA1 terminal LINE OUTPUT (canal izquierdo)	VR507	Onda senoidal	

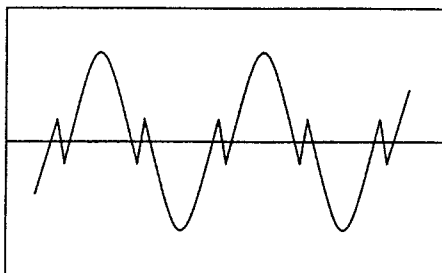
● Forma de onda de la distorsion del punto de intersección del eje con cero



OK



NG



NG

8. FOR SD TYPE

NOTES :

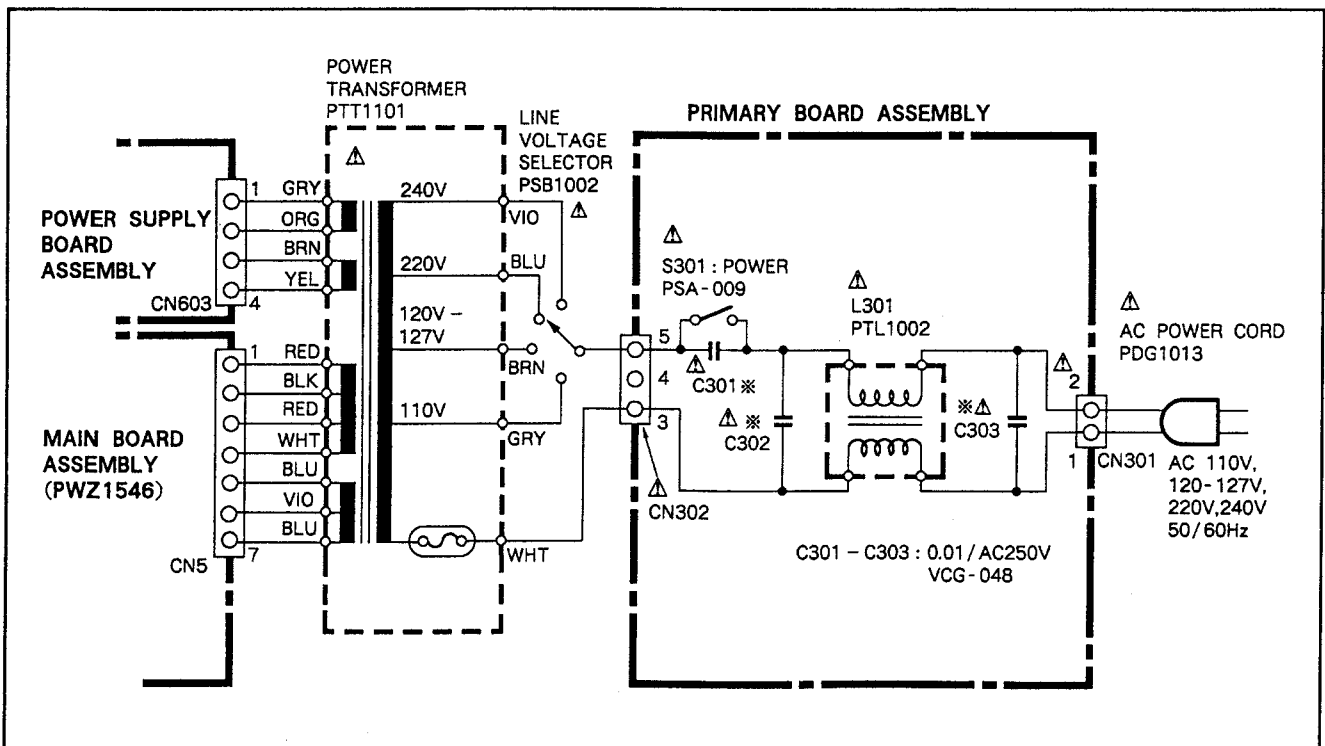
- Parts without part number cannot be supplied.
- The Δ mark found on some component parts indicates the importance of the safety factor of the part. Therefore, when replacing, be sure to use parts of identical designation.
- Parts marked by "⊙" are not always kept in stock. Their delivery time may be longer than usual or they may be unavailable.

8.1 CONTRAST OF MISCELLANEOUS PARTS

The PD-71/SD type is the same as the PD-71/KU/CA type with the exception of the following sections.

Mark	Symbol & Description	Part No.		Remarks
		PD-71/KU/CA type	PD-71/SD type	
Δ	AC power cord	PDG1015	PDG1013	For packing
Δ	CD packing case	PHG1308	PHG1331	
Δ	Power transformer (AC120V)	PTT1099	•••••	
Δ	Power transformer (AC110V/120 - 127V/220V/240V)	•••••	PTT1101	
Δ	Line voltage selector (AC110V/120 - 127V/220V/240V)	•••••	PSB1002	
	Front panel assembly	PYY1099	PYY1111	

8.2 SCHEMATIC DIAGRAM FOR SD TYPE



9. FOR PD-9300/HEM AND HB TYPES

NOTES :

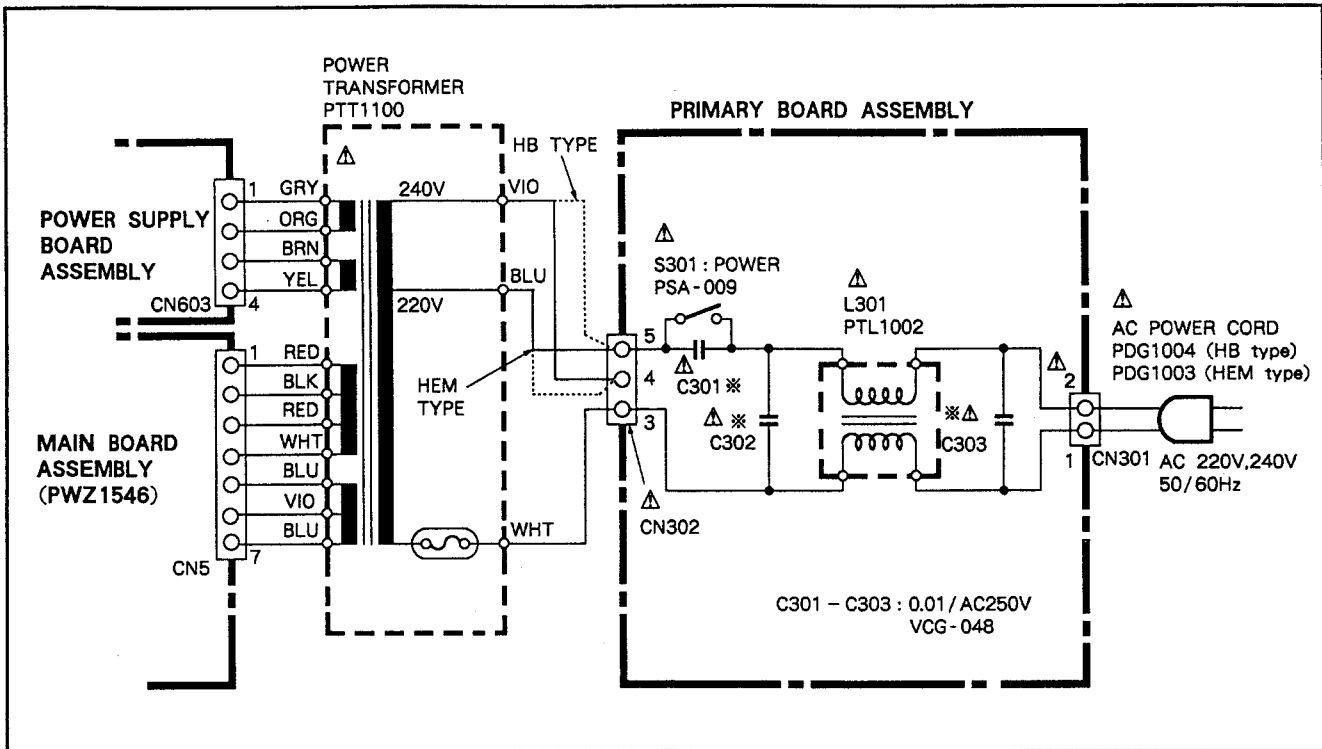
- Parts without part number cannot be supplied.
- The Δ mark found on some component parts indicates the importance of the safety factor of the part. Therefore, when replacing, be sure to use parts of identical designation.
- Parts marked by "⊙" are not always kept in stock. Their delivery time may be longer than usual or they may be unavailable.

9.1 CONTRAST OF MISCELLANEOUS PARTS

The PD-9300/HEM and HB types are the same as the PD-71/KU/CA type with the exception of the following sections.

Mark	Symbol & Description	Part No.			Remarks
		PD-71/ KU/CA type	PD-9300/ HEM type	PD-9300/ HB type	
Δ	Strain relief FL sheet Door name plate Side sash (L) Side sash (R)	CM-22C PAM1290 PAN1132 Non supply Non supply	CM-22B PAM1251 PAN1121 • • • • • • • • • •	CM-22B PAM1251 PAN1121 • • • • • • • • • •	
Δ	AC power cord Plate spring Side rubber Protector (F) Protector (R)	PDG1015 PBK1061 • • • • • PHA1095 PHA1096	PDG1003 • • • • • PEB1104 PHA1080 PHA1081	PDG1004 • • • • • PEB1104 PHA1080 PHA1081	For: packing For: packing
	CD packing case Screw Side wood (L) Side wood (R) Wood collar	PHG1308 PBA1038 Non supply Non supply Non supply	PHG1310 •	PHG1310 •	For: packing
Δ	Power transformer (AC120V)	PTT1099	• • • • •	• • • • •	
Δ	Power transformer (AC220V/240V)	• • • • •	PTT1100	PTT1100	
	Remote control unit Front panel assembly	PWW1037 PYY1099	PWW1028 PYY1108	PWW1028 PYY1108	
	Insulator sheet B Operating instructions (English) Operating instructions (Spanish/Portgause/Swedish/ Dutch)	VEC-236 PRB1085 • • • • •	• • • • • • • • • • PRF1021	• • • • • PRB1085 • • • • •	
	Operating instructions (English/French/German/Italian)	• • • • •	PRE1083	• • • • •	

9.2 SCHEMATIC DIAGRAM FOR PD-9300/HEM AND HB TYPES



● Line Voltage Selection

Line voltage can be changed with the following steps.

1. Disconnect the AC power cord.
2. Remove the bonnet case.
3. Change the connection wires from the power transformer (VIO (240V) and BLU (220V) wires) to the PRIMARY BOARD assembly (CN302 pin 4 and pin 5) as shown in the schematic diagram.
4. Stick the line voltage label on the rear panel.

Description	Part No.
220V label	AAX-193
240V label	AAX-192

10. SPECIFICATIONS

1. General

Type Compact disc digital audio system
Usable disc Compact Disc

Power requirements

European models AC 220V, 50/60Hz
U.K., Australian models AC 240V, 50/60Hz
U.S., Canadian models AC 120V, 60Hz
Other models AC 110/120 - 127/220/240V
(switchable), 50/60Hz

Power consumption 21 W
Operating temperature +5°C - +35°C
(+41°F- +95°F)

PD-9300:

Weight 8.5 kg (18 lb, 12 oz)
External dimensions
420(W) × 320(D) × 127(H) mm
16-9/16(W) × 12-19/32(D) × 5(H) in

PD-71:

Weight 9.5 kg (20 lb, 15 oz)
External dimensions
457(W) × 324(D) × 127(H) mm
18(W) × 12-3/4(D) × 5(H) in

2. Audio section

Frequency response 2 Hz - 20 kHz (±0.3 dB)
Signal-to-noise ratio 112 dB or more (EIAJ)
Dynamic range 99 dB or more (EIAJ)
Channel separation 108 dB or more (EIAJ)
Total harmonic distortion 0.002 or less (EIAJ)
Output voltage 2 V
Wow and flutter Limit of measurement
(±0.001% W.PEAK) or less (EIAJ)
Number of channels 2 channels (stereo)
Digital output Coaxial output: 0.5 Vp-p (75 Ω)
Optical output: , -15 dBm to -20 dBm
(wavelength 660 nm)

3. Output terminal

Optical digital output terminal
Coaxial digital output terminal
Audio line output terminal

4. Functions

- PLaY
- Stop
- Pause
- Manual search
- Track search
- Index search
- Direct selection
- Single track repeat
- All track repeat
- Programmed repeat
- Random play repeat
- Programmed random play repeat
- Programmed playback (up to 24 tracks)
- Program check
- Program correction
- Program clear
- Pause program
- Add-on program
- Random play
- Programmed random play
- Display off
- Digital/Analog output selector
- Timer start
- Time display switchover

5. Accessories

- Remote control unit 1
- Size AAA/R03 dry cell batteries 2
- Output cable 1
- Operating instructions 1

NOTE: _____
Specifications and design subject to possible modifications
without notice, due to improvement.

11. PANEL FACILITIES

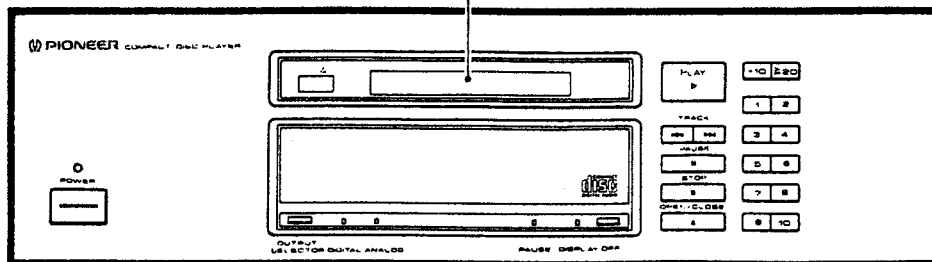
FRONT PANEL

INDICATORS

- PROGRAM : Lights during the program mode.
- RANDOM : Lights during random playback.
- AUTO SPACE : Lights during auto space playback.
- ▶ REPEAT : Lights during repeat playback of one track.
- REPEAT : Lights during repeat playback of all tracks (or programs).
- TRACK : Displays the current track number (during normal playback and programmed playback) or the track being programmed during programming operation.
- INDEX : Displays the index* number of the music section of a track or the track division.
- STEP : Displays the program steps.
- TIME/REMAIN/TOTAL : Changes each time the TIME key is pressed.
 - TIME : Displays the track number of the track being displayed (TRACK) and the elapsed time (minutes and seconds).
 - REMAIN : Displays the remaining time on the track being displayed. When the TIME key is pressed again, the remaining time on the disc will be displayed.
 - TOTAL : Displays the total number of tracks on the disc (TRACK) and the overall playback time (minutes and seconds). During playback, the display goes on for about 5 seconds before changing to the TIME display.

During programmed playback operation, displays the playing time, the remaining time of the track being played and the total program steps (TOTAL).
 MIN (minute) : Displays the minutes of the elapsed time, total playback time, and remaining time.
 SEC (second) : Displays the seconds of the elapsed time, total playback time, and remaining time.

* The INDEX is a signal which is recorded within a track to indicate division of the track into separate tunes and items of music.



PLAY key/indicator (▷)
 Press to begin playback, and to cancel the pause mode.

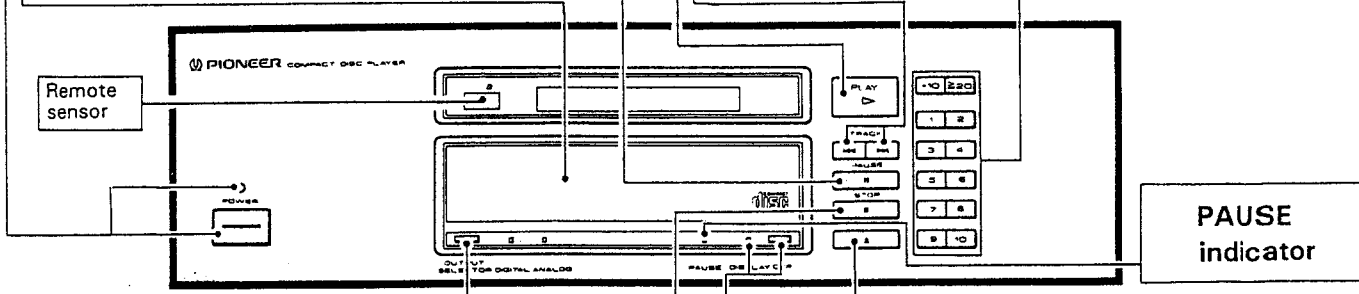
POWER switch / indicator
 Press to turn power ON and OFF to the unit. If there is a disc in the unit when power is turned ON, playback will begin automatically. (Timer start function)

Disc Tray
 This is where the disc is set. When power is switched ON and the OPEN/CLOSE key is pressed, the tray is ejected forward. To insert the tray, press the OPEN/CLOSE key, or lightly push the tray in with your finger. With the disc tray open, pressing the PLAY key or TRACK NUMBER key will close the disc tray and start playback.

PAUSE key (|||)
 Press to temporarily interrupt playback. When pressed again, the pause mode is cancelled and playback resumes. When pressed during program mode, a pause is inserted into the program.

TRACK SEARCH keys
 During playback (or programmed play) or pause, these keys are used to search for the desired track. The search keys are pressed to advance or reverse the player to the next or previous track respectively.
 [▶▶]: Pressing this key once will advance the player to the beginning of the next track. Holding down the key will advance the player to the beginning of the following tracks. (During programmed playback, the player will advance to the beginning of the following programmed track(s).)
 [◀◀]: Pressing this key once will reverse the player to the beginning of the currently-playing track. Holding down the key will reverse the player to the beginning of the previous track (s). [During programmed playback, the player will reverse to the beginning of the previous programmed track (s)].

TRACK NUMBER keys (1 to 10, +10 and ≥ 20)
 These keys are used to specify the track numbers (tracks 1 to 99) for direct track selection or program entry.



OUTPUT SELECTOR key/indicator
 Use this key to select the desired output terminals. The default setting for both outputs is ON and with subsequent pressing of the key the terminal assignment will change as follows.

	Digital Output	Analog Output
Power is applied	ON	ON
Key stroke 1	OFF	ON
Key stroke 2	ON	OFF
Key stroke 3	ON	ON

- The indicator lits.
- Unused circuits are not activated, thus eliminating any adverse effect on the sound quality.

OPEN/CLOSE key (▲)
 Press when you wish to eject or load a disc. Each time the key is pressed, the tray is alternately pushed out or pulled in.

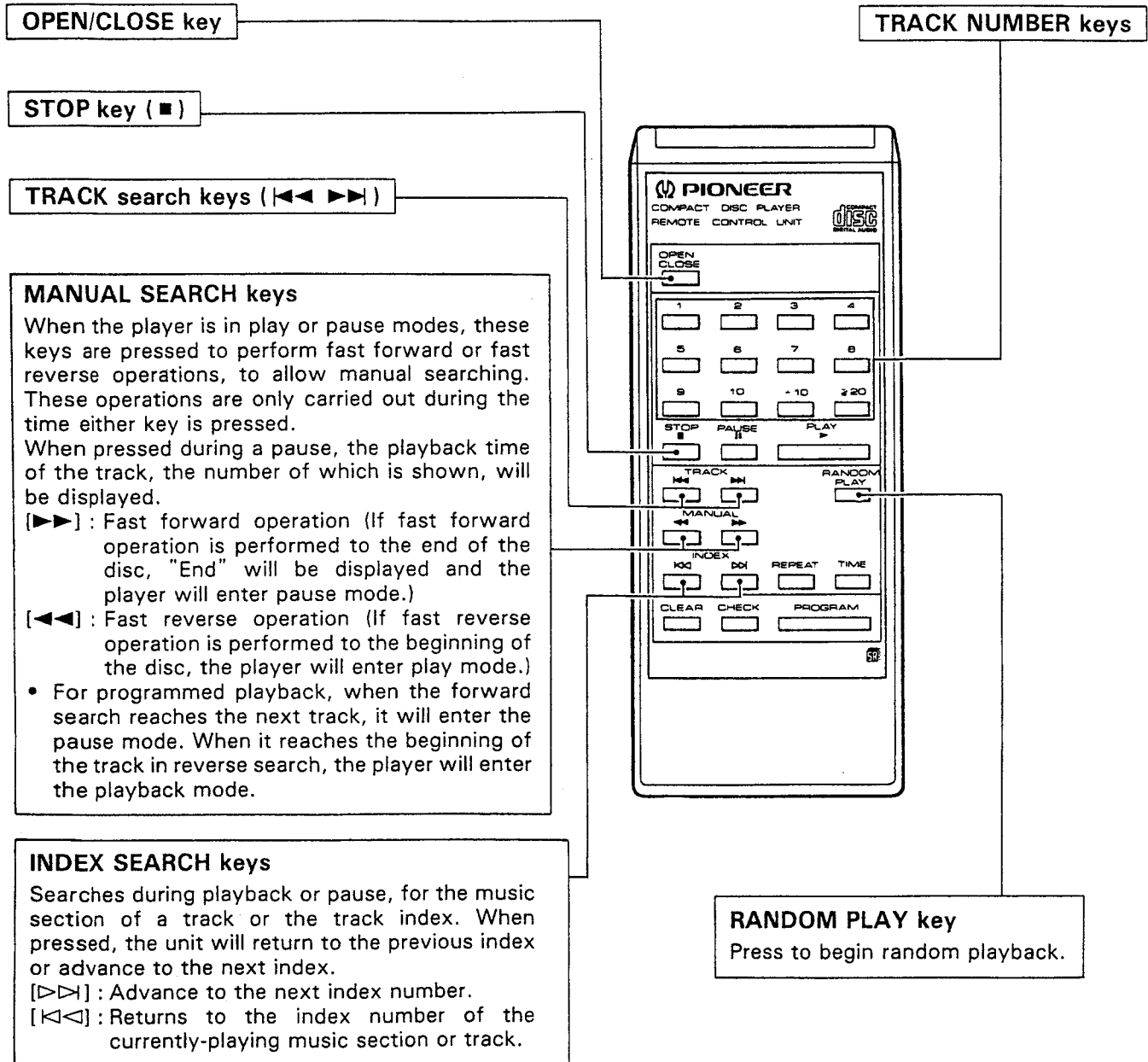
DISPLAY OFF key / indicator
 Press this key to turn off the indicator display. The unused circuits are turned off to prevent any detrimental effect on sound quality.

- When an operation key is pressed, the display will go on for a few seconds.
- When not in playback mode (STOP, PAUSE, etc.), the display will be on.

STOP key (■)
 Press to stop playback. When pressed, the player goes into stop mode and all operations stop. Press to clear a program. When pressed during stop mode, the program stored in memory is cleared.

REMOTE CONTROL UNIT

Refer to player front panel section regarding other key functions not specified here.



REPEAT key

Press this key for repeat playback. Pressing the key once, twice, or three times will change the repeat mode from single track repeat, all tracks repeat, and repeat playback cancellation.

Single track repeat:

The currently-playing track will repeat. The key can be used during normal playback, program playback, random playback.

All tracks repeat:

All tracks on the disc will be repeated.

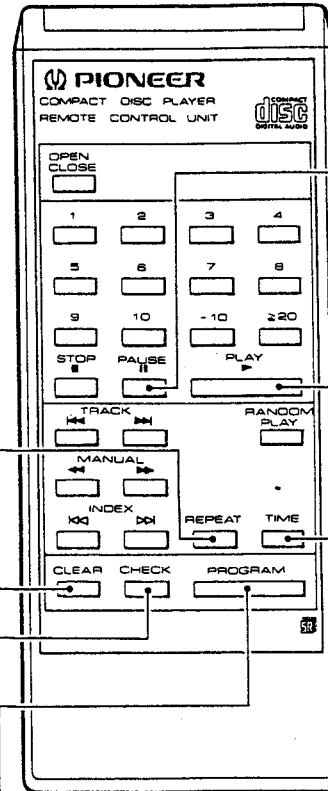
- If pressed during normal playback mode, all tracks on the disc will be repeatedly played back.
- If pressed during programmed playback, the programmed tracks will be repeatedly played back in the programmed order.
- In the case of random play mode, after all the tracks have been played, random play will start again.
- During programmed random playback, after the programmed tracks are played at random, programmed random playback will be repeated.

CLEAR key

Press this key during program entry or playback to clear the last program step.

CHECK key

Press this key to check the contents of a program that has been entered. Starting with step 1 of the program, the next program step will be shown each time the key is pressed.



PAUSE key (||)

PLAY key (▶)

TIME key

This switches the indicator display mode. Each time the key is pressed, the display will show TIME, REMAIN, and TOTAL respectively. (For a description of each display mode, refer to the item concerning the indicator.)

PROGRAM key

This is used to program tracks to play in a desired sequence. Press this key to set the unit to program mode. then specify the desired tracks with the TRACK NUMBER keys. The tracks will be programmed as they are entered in this way.

REAR PANEL

